



## Car Lift

3D Wheel Alignment Machine

Car Frame Machine

Paint Spray booth

Tire Changer

Wheel Balancer

FACTORY DIRECTLY



Yantai Jingli Automobile Testing Equipment Co.,Ltd  
<https://en.jingli-ame.com>



# COMPANY PROFILE

Yantai Jingli automotive testing equipment co.,Ltd is located in the beautiful and fertile mountain city - Yantai. The company covers an area of more than 8000 square meters, and it owns independent technical center, perfect production and convenient, efficient after-sales service system, specializing in automotive testing equipment research and development design, manufacturing and selling well both at home and abroad market. Our company has the rights of import and export.

Our main products: 3D wheel alignment machine, two post car lift, clear-floor two post car lift, double decks scissor car lift, single deck scissor car lift, tire changer, tire balancer, spray booth, car frame machine (whole bench moveable, square holes, bolt holes, European export style), products can be customized according to customer needs.

Our company own Ten thousand watt laser cutting machine, Integrated steel plate bending machine, robot welding, Spray paint, Waterproof rustproof and other advanced production equipment and technology as well as strict quality inspection process

The company's Research and Development team closely focuses on the latest international technology, constantly bring forth the new, according to customer needs, producing safe and practical, high quality car maintenance and testing equipment for customer.



# HIGH ADVANCED PRODUCTION EQUIPMENTS



Laser cutting machine



Digital bending machine



Welding by robot



CNC center drilling



Automatic spraying line



FCL shipment

# CE CERTIFICATE



**SPIRIT OF ENTERPRISE**

Pursuit of excellence  
Innovate and forge ahead



**Purpose**

Factory direct sales  
Serve every customer



**Brand Image**

Technical team



**Core Values**

Refinement of quality  
After sale guarantee

## TWO POST FLOOR BASE CAR LIFT



Multi-tooth arm lock



8 piece chain



Solid steel plate



Limit switch(optional)



Add feet(optional)



Foot safety bar(optional)

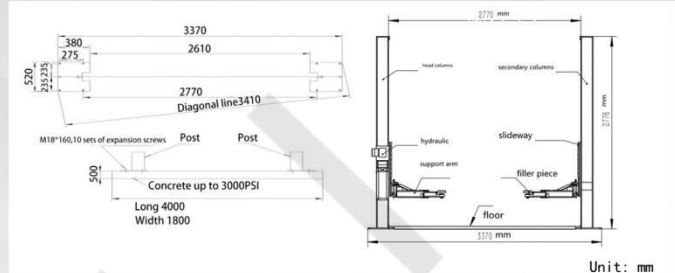

Technical Parameters	
Model no.	JL830
Lifting weight	4t (8818lb)
Lifting weight (Optional)	4.5t (9920lb) /5t (11023lb)
Lifting weight (Optional)	5.5t (12125lb) /6t (13228lb)
Initial height	110mm (4in)
Lifting height	1850mm (73in)
Column height	2776mm (109in)
Column inner width	2770mm (109in)
Column overall width	3370mm (133in)
Arm length	755-1130mm (30-45in)
Lifting time	$t \geq 55s$
Lowering time	$20s \leq t \leq 40s$
Power voltage	220v/380v
Motor power	2.2kw

- Double column integrated whole plate bending.
- Double cylinder, inner wall mirror treatment.
- Laser cutting, accurate size, smooth incision.
- Shot blasting, electrostatic powder spraying process.
- Two cables are connected, and two slides move synchronously.
- Retractable bracket, convenient maintenance.
- Door protective rubber mat.
- Pickup arm initial height 110 mm.
- Pure copper motor.

## TWO POST FLOOR BASE CAR LIFT MECHANICAL UNLOCKING



Multi-tooth arm lock



8 piece chain



Mechanical unlocking

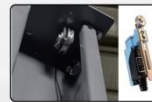

Limit switch(optional)



Add feet(optional)



Foot safety bar(optional)

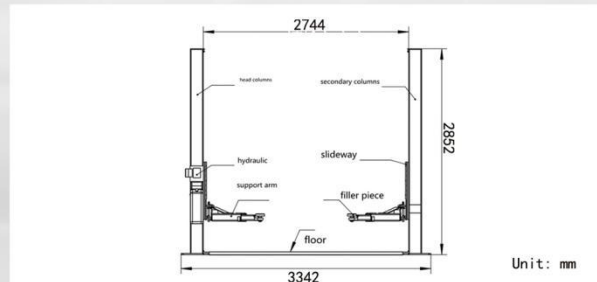

Technical Parameters	
Model no.	JL850
Lifting weight	4t (8818lb)
Lifting weight (Optional)	4.5t (9920lb) /5t (11023lb)
Lifting weight (Optional)	5.5t (12125lb) /6t (13228lb)
Lifting height	1850mm (73in)
Initial height	110mm (4in)
Overall height	2852mm (112in)
Columns within wide	2744mm (108in)
Overall width	3342mm (132in)
Arm length	755-1130mm (30-44in)
Lifting time	$t \geq 55s$
Falling time	$20s \leq t \leq 40s$
Power voltage	220v/380v
Motor power	2.2kw
Working pressure	22Mpa

- Double column column whole plate bending.
- Double cylinder, cylinder wall mirror treatment.
- Mechanical unilateral unlock setting.
- Laser cutting, accurate size.
- Shot blasting treatment, electrostatic powder spraying.
- Two cables are connected, two slides move synchronously.
- Retractable bracket for maintenance.
- Door protective rubber mat.
- Pickup arm initial height 110 mm.
- Pure copper motor.

## TWO POST FLOOR BASE CAR LIFT ELECTROLYTIC LOCK



### Technical Parameters

Model no.	JL860E
Lifting weight	4t (8818lb)
Lifting weight (Optional)	4.5t (9920lb) / 5t (11023lb)
Lifting weight (Optional)	5.5t (12125lb) / 6t (13228lb)
Lifting height	1850mm (73in)
Initial height	110mm (4in)
Overall height	2784mm (110in)
Columns within wide	2744mm (108in)
Overall width	3342mm (132in)
Arm length	755-1130mm (30-44in)
Lifting time	$t \geq 55s$
Falling time	$20s \leq t \leq 40s$
Power voltage	220v/380v
Motor power	2.2kw
Working pressure	22Mpa



Multi-tooth arm lock



8 piece chain



Electric power unlock



Limit switch (optional)



Add feet (optional)



Foot safety bar (optional)

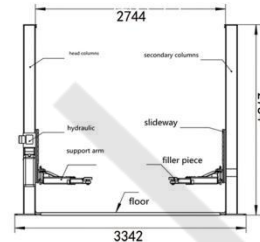

- Double column column whole plate bending.
- Double cylinder, cylinder wall mirror treatment.
- Electrolytic lock setting.
- Laser cutting, accurate size.
- Shot blasting treatment, electrostatic powder spraying.
- Two cables are connected, and two slides move synchronously.
- Retractable bracket for maintenance.
- Door protective rubber mat.
- Pickup arm initial height 110 mm.
- Pure copper motor.

## TWO POST FLOOR CLEAR CAR LIFT



### Technical Parameters

Model no.	JL986
Lifting weight	4t (8818lb)
Lifting weight (Optional)	4.5t (9920lb) / 5t (11023lb)
Lifting weight (Optional)	5.5t (12125lb) / 6t (13228lb)
Initial height	110mm (4in)
Lifting height	1850mm (73in)
Column height	3830mm (151in)
Column inner width	2744mm (108in)
Column overall width	3392mm (134in)
Arm length	755-1130mm (30-45in)
Lifting time	$t \geq 55s$
Lowering time	$20s \leq t \leq 40s$
Power voltage	220v/380v
Motor power	2.2kw



Multi-tooth arm lock



8 piece chain



Solid steel plate



Power unit



Add feet (optional)



Foot safety bar (optional)

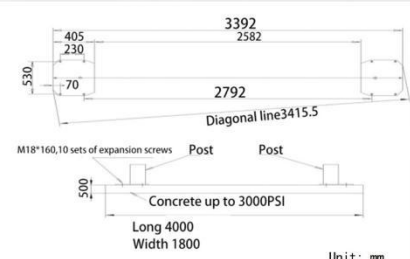
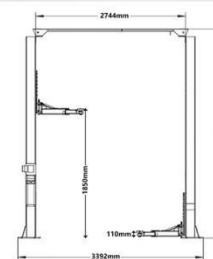

- Gantry column integrated whole plate bending.
- Double cylinder, inner wall mirror treatment.
- Laser cutting, accurate size, smooth incision.
- Shot blasting, electrostatic powder spraying process.
- Two cables are connected, and two slides move synchronously.
- Retractable bracket, convenient maintenance.
- Door protective rubber mat.
- Pickup arm initial height 110 mm.
- Pure copper motor.

## TWO POST FLOOR CLEAR CAR LIFT MECHANICAL UNLOCKING



### Technical Parameters

Model no.	JL886
Lifting weight	4t (8818lb)
Lifting weight (Optional)	4.5t (9920lb) / 5t (11023lb)
Lifting weight (Optional)	5.5t (12125lb) / 6t (13228lb)
Lifting height	1850mm (73in)
Post height	3828mm (151in)
Columns within wide	2744mm (108in)
Overall width	3342mm (132in)
Lifting time	$t \geq 55s$
Falling time	$20s \leq t \leq 40s$
Hydraulic pressure	22Mpa
Power voltage	220v/380v
Motor power	2.2kw



Multi-tooth arm lock

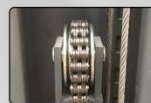

8 piece chain



Solid steel plate



Mechanical unlocking



Add feet (optional)



Foot safety bar (optional)

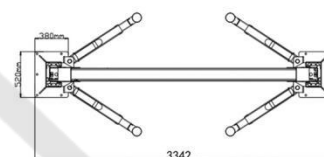
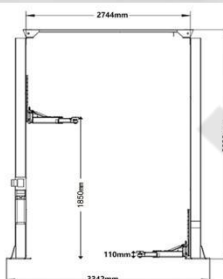

Unit: mm

- Dragon gate post integral plate bending.
- Double cylinder, cylinder wall mirror treatment.
- Mechanical unilateral unlock setting.
- Laser cutting, accurate size.
- Shot blasting treatment, electrostatic powder spraying.
- Two cables are connected, and two slides move synchronously.
- Retractable bracket for maintenance.
- Door protective rubber mat.
- Pickup arm initial height 110 mm.
- Pure copper motor.

## TWO POST FLOOR CLEAR CAR LIFT ELECTROLYTIC LOCK



### Technical Parameters

Model no.	JL786E
Lifting weight	4t (8818lb)
Lifting weight (Optional)	4.5t (9920lb) / 5t (11023lb)
Lifting weight (Optional)	5.5t (12125lb) / 6t (13228lb)
Lifting height	1850mm (73in)
Post height	3828mm (151in)
Columns within wide	2744mm (108in)
Overall width	3342mm (132in)
Lifting time	$t \geq 55s$
Falling time	$20s \leq t \leq 40s$
Hydraulic pressure	22Mpa
Power voltage	220v/380v
Motor power	2.2kw



Multi-tooth arm lock

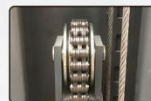

8 piece chain



Solid steel plate



Electric power unlock



Add feet (optional)



Foot safety bar (optional)

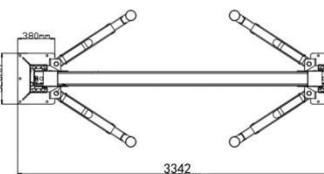
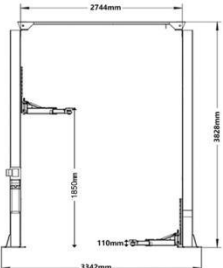

Unit: mm

- Dragon gate post integral plate bending.
- Double cylinder, cylinder wall mirror treatment.
- Electrolytic lock setting.
- Laser cutting, accurate size.
- Shot blasting treatment, electrostatic powder spraying.
- Two cables are connected, and two slides move synchronously.
- Retractable bracket for maintenance.
- Door protective rubber mat.
- Pickup arm initial height 110 mm.
- Pure copper motor.

### UNDER-GROUND SCISSOR CAR LIFT



One solid steel plate laser cutting



Oil filling port



Lift long wheelbase cars

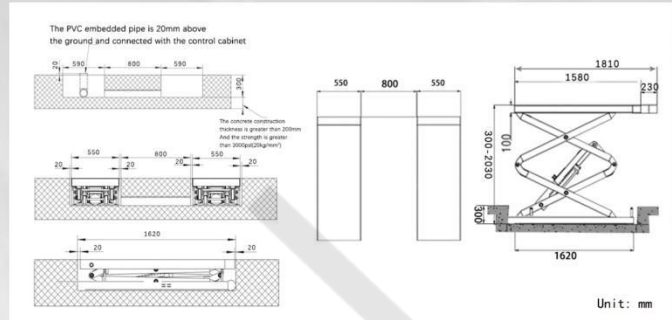

#### Technical Parameters

Model no.	JL300D
Lifting weight	3500kg (7716lb)
Lifting weight (Optional)	4000kg (8818lb)
Initial height	300mm (12in)
Lifting height	2030mm (80in)
Overall length	1580-1810mm (62-71in)
Runway plate width	550mm (22in)
Runways clearance	800mm (32in)
Voltage	220v/380v
Motor power	2.2kw

- Excavation type installation, does not occupy space.
- Table stretch extension, SUV, pickup truck, car, commercial vehicle, etc.
- Hydraulic synchronization, hydraulic lock and mechanical double safety device, drop with alarm device.
- Cylinder wall mirror processing, imported seals and ball valves.
- Laser cutting technology, accurate size, smooth incision, high finish.
- The shaft position has wear-resistant copper sleeve, built-in oil injection port.
- Shot blasting, electrostatic powder spraying process, waterproof and embroidery proof.

### UNDER-GROUND SCISSOR CAR LIFT DOUBLE STRETCH



One solid steel plate laser cutting



Oil filling port



Lift long wheelbase cars

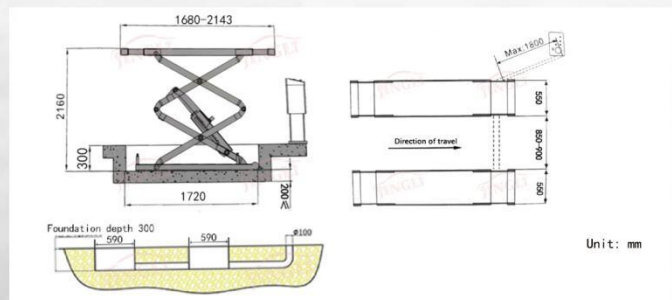

#### Technical Parameters

Model no.	JL300DS
Lifting weight	3500kg (7716lb)
Lifting weight (Optional)	4000kg (8818lb)
Initial height	300mm (12in)
Lifting height	2160mm (85in)
Overall length	2143mm (84in)
Runway plate width	550mm (22in)
Runways clearance	850-900mm (33-35in)
Voltage	220v/380v
Motor power	2.2kw

- Excavation type installation, does not occupy space.
- Table stretch extension, SUV, pickup truck, car, commercial vehicle, etc.
- Hydraulic synchronization, hydraulic lock and mechanical double safety device, drop with alarm device.
- Cylinder wall mirror processing, imported seals and ball valves.
- Laser cutting technology, accurate size, smooth incision, high finish.
- The shaft position has wear-resistant copper sleeve, built-in oil injection port.
- Shot blasting, electrostatic powder spraying process, waterproof and embroidery proof.

### ABOVE-GROUND SCISSOR LIFT



The scissors arm is 25mm thick



Four cylinders, lock tooth laser cutting



Large booster arm

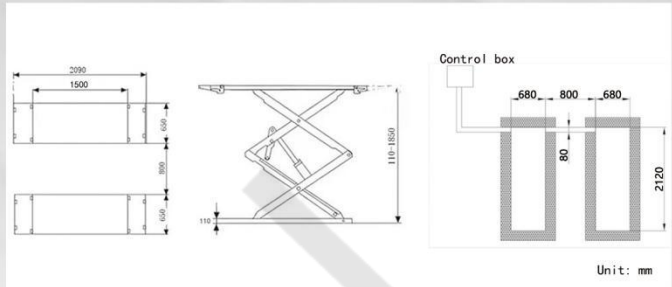

#### Technical Parameters

Model no.	JL300C
Lifting weight	3500kg (7716lb)
Initial height	110mm (4in)
Lifting height	1850mm (73in)
Overall length	1500-2090mm (59-82in)
Runway plate width	650mm (26in)
Runways clearance	800mm (32in)
Voltage	220v/380v
Motor power	2.2kw

- Table extension, long wheelbase vehicle.
- 4 cylinder structure, double hydraulic system, hydraulic lock and mechanical triple insurance, drop alarm device.
- Cylinder inner wall mirror treatment.
- Laser cutting, smooth incision.
- Scissors arm solid steel plate, high quality solid steel plate laser cutting.
- Large booster arm, increase lifting power.
- The shaft has wear-resistant copper sleeve, built-in oil injection port, polymer wear-resistant slider.
- Shot blasting, electrostatic powder spraying process, waterproof and embroidery proof.

### MID-RISE PORTABLE CAR LIFT MACHINE



Lock tooth double protection



Solid scissors arm, built-in oil injection port



Booster arm

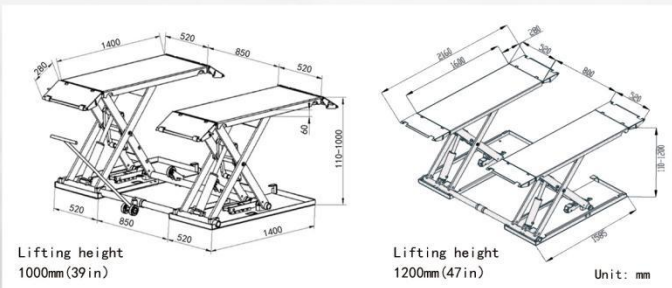

#### Technical Parameters

Model no.	YD-A2
Lifting weight	3500kg (7716lb)
Initial height	110mm (4in)
Lifting height (Optional)	1000mm (39in) / 1200mm (47in)
Overall length (Optional)	1960mm (77in) / 2160mm (85in)
Runway plate width	520mm (20in)
Runways clearance (Optional)	850mm (33in) / 800mm (31in)
Voltage	220v/380v
Motor power	2.2kw

- Table extension, long wheelbase vehicle.
- Hydraulic lock and mechanical double insurance, drop alarm device.
- Cylinder inner wall mirror treatment.
- Laser cutting, smooth incision.
- Scissors arm solid steel plate, high quality solid steel plate laser cutting.
- Large booster arm, increase lifting power.
- The shaft has wear-resistant copper sleeve, built-in oil injection port, polymer wear-resistant slider.
- Shot blasting, electrostatic powder spraying process, waterproof and embroidery proof.

## ONGROUND LARGE SCISSOR CAR LIFT



Laser integrated three teeth



Large booster arm

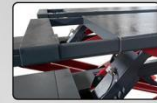

Extension of sub-shear

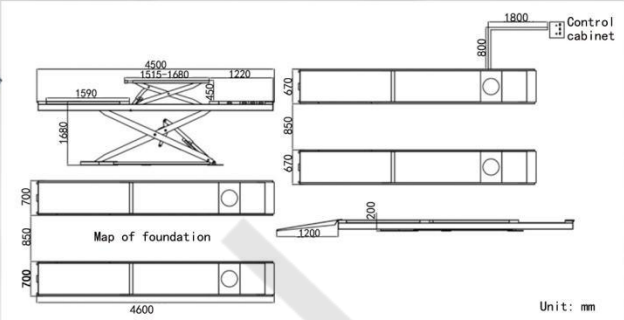

### Technical Parameters

Model no.	JL6000D
First scissor lifting weight	4000kg (8818lb)
First scissor lifting weight (Optional)	4500kg (9921lb)
Second scissor lifting weight	3500kg (7716lb)
Initial height	200mm (8in)
First scissor lifting height	1680mm (66in)
Second scissor lifting height	450mm (18in)
First platform length	4500-5700mm (177-224in)
Second platform length	1515-1680mm (60-66in)
First platform width	670mm (26in)
Second platform width	600mm (24in)
Runways clearance	850mm (33in)
Voltage	220v/380v
Motor power	2.2kw/3.0kw

- The table can be moved at will, suitable for all kinds of vehicles, SUV, pickup truck, car, commercial vehicle.
- 6 cylinders, double hydraulic system, hydraulic lock and mechanical triple insurance, drop alarm device.
- Cylinder wall mirror processing, imported seals and ball valves.
- Laser cutting, accurate size, smooth incision, high finish.
- Scissor arm 25mm thick made by one solid steel plate laser cutting, no deformation.
- Single side stretchable shear.
- The shaft has wear-resistant copper sleeve and built-in oil filling port.
- Shot blasting treatment electrostatic powder spraying, waterproof and embroidery proof.

## UNDERGROUND LARGE SCISSOR CAR LIFT



One solid steel plate laser cutting



Air lock, mechanical lock



Built-in oil filling port

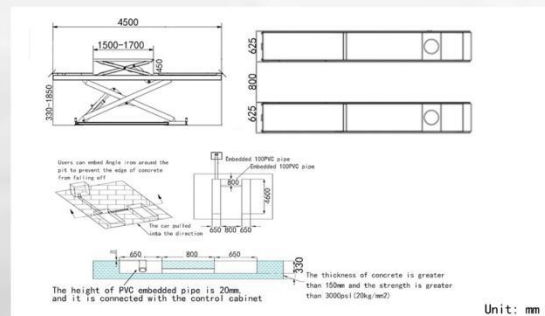

### Technical Parameters

Model no.	JL4000D
First scissor lifting weight	4000kg (8818lb)
First scissor lifting weight (Optional)	5000kg (11023lb)
Second scissor lifting weight	3500kg (7716lb)
Initial height	330mm (13in)
First scissor lifting height	1850mm (73in)
Second scissor lifting height	450mm (18in)
First platform length	4500mm (177in)
First platform length (Optional)	4800mm (189in)
First platform length (Optional)	5000mm (197in)
Second platform length	1500-1700mm (59-67in)
First platform width	625mm (25in)
Runways clearance	800mm (32in)
Voltage	220v/380v
Motor power	2.2kw/3.0kw

- The table can be moved at will, suitable for all kinds of vehicles, SUV, pickup truck, car, commercial vehicle.
- Hydraulic lock and mechanical double safety device.
- Laser cutting, accurate size, smooth incision, high finish.
- Scissor arm 25mm thick made by one solid steel plate laser cutting, no deformation.
- Cylinder wall mirror processing, imported seals and ball valves.
- Single side stretchable shear.
- The shaft has wear-resistant copper sleeve and built-in oil filling port.
- Shot blasting treatment electrostatic powder spraying, waterproof and embroidery proof.

## FOUR POST CAR LIFT



Double lift biaxial stretching



Steel pulley block, steel core rope



Convenient positioning of worktable

### Technical Parameters

Model no.	JL460
Lift up weight	4000kg (8818lb)
Height of lift	1750mm (69in)
Minimum height	220mm (8.7in)
Length of platform	4500mm (177in)
Total equipment length	5860mm (231in)
Total width of equipment	3340mm (132in)
Width between columns	3000mm (118in)
Single lane width	550mm (22in)
Platform outer spacing	2050/2125/2200mm (21/84/87in)
Height of column	2015mm (79in)
Secondary lift height	350mm (14in)
Secondary lift length	800-1215mm (31-48in)
Voltage voltage	380v
Motor power	2.2kw

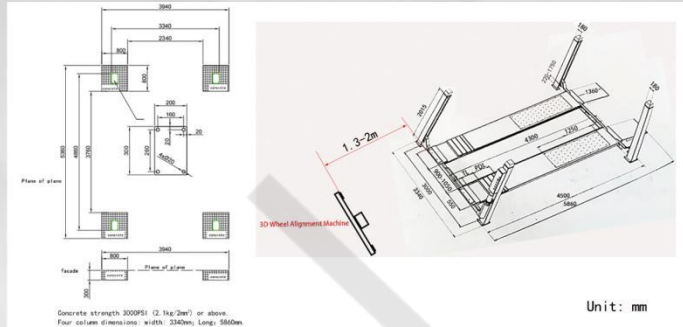

- The table can be moved, convenient positioning.
- Shot blasting, electrostatic powder spraying process, waterproof and embroidery proof.
- Manual mechanical unlocking.
- Cylinder inner wall mirror treatment.
- Hydraulic and overload safety valve protection.
- Extended rear wheel side skateboard, front wheel corner disc position can be adjusted.
- Adjustable platform inner distance.
- Integrated three-tooth lock tooth, laser cutting.

## FOUR POST CAR LIFT

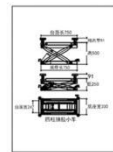
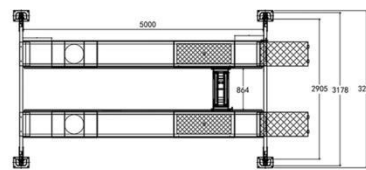
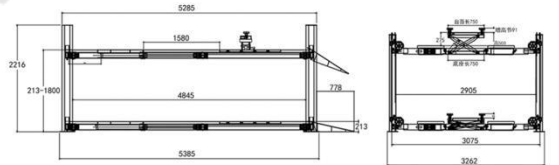

Unit: mm

### Technical Parameters

Model no.	JL460-5.0
Lift up weight	5000kg (11023lb)
Height of lift	1800mm (71in)
Length of platform	5000mm (197in)
Time of rise	<110s
Time of fall	<110s
Minimum height	213mm (8in)
Runway spacing	864mm (34in)
Length of upper plate	778mm (31in)
Total length of equipment	6063mm (239in)
Total width of equipment	3260mm (128in)
Height of column	2216mm (87in)

- The table can be moved, convenient positioning.
- Shot blasting, electrostatic powder spraying process, waterproof and embroidery proof.
- Cylinder inner wall mirror treatment.
- Hydraulic and overload safety valve protection.
- Integral bending of the column bending machine.
- Table width and length, suitable for long wheelbase models.
- With secondary lift, increase lift height.

## FOUR POST CAR LIFT

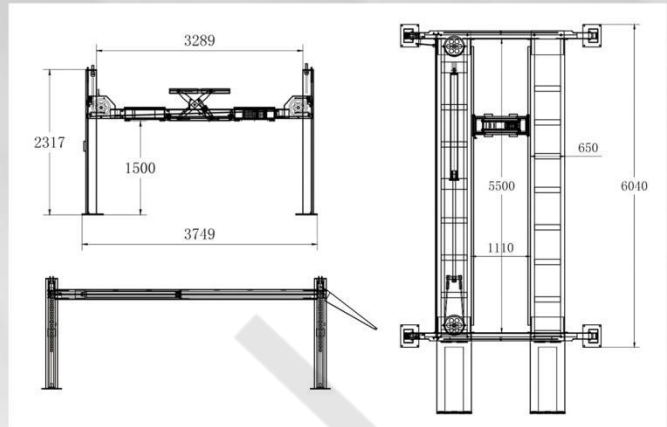

### Technical Parameters

Model no.	JL460-6.0
Lift up weight	6000kg(11023lb)
Height of lift	1500mm(59in)
Length of table	5500mm(216.5in)
Width of runway	650mm(25.6in)
Table spacing	1110mm(44in)
Length of equipment	6040mm(238in)
Total width of equipment	3749mm(147.6in)
Width inside the column	3289mm(129in)
Height of column	2317mm(91in)

- The table can be moved, convenient positioning.
- Shot blasting, electrostatic powder spraying process, waterproof and embroidery proof.
- Cylinder inner wall mirror treatment.
- Hydraulic and overload safety valve protection.
- Integral bending of the column bending machine.
- Table width and length, suitable for long wheelbase models.
- With secondary lift, increase lift height.

## FOUR POST CAR LIFT

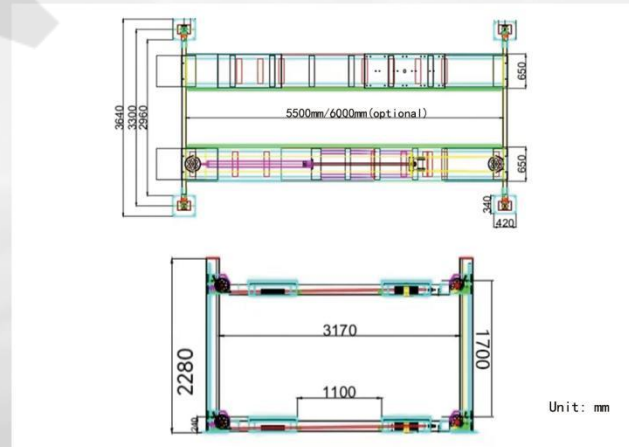

### Technical Parameters

Model no.	JL460-8.0
Lift up weight	8000kg(17637lb)
Height of lift	1700mm(67in)
Height of landing	240mm(1in)
Length of platform(Optional)	5500mm(217in)/6000mm(236in)
Total width	3640mm(143in)
Width of runway	650mm(26in)
Height of column	2280mm(90in)
Runway spacing	1100mm(43in)
Width between columns	3170mm(125in)

- The table can be moved, convenient positioning.
- Shot blasting, electrostatic powder spraying process, waterproof and embroidery proof.
- Cylinder inner wall mirror treatment.
- Hydraulic and overload safety valve protection.
- Integral bending of the column bending machine.
- Table width and length, suitable for long wheelbase models.
- With secondary lift, increase lift height.

## ELEVADOR PARA CARROS DE QUATRO PILARES

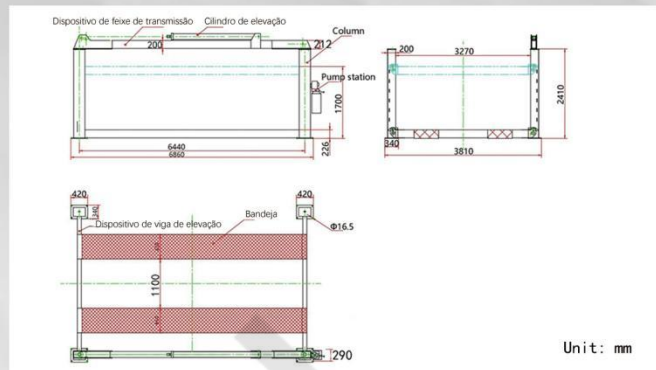

Technical Parameters	
Model no.	JL460-8.0/JL460-10.0
lifting capacity	8000KG (17637lb)
lifting capacity (Optional)	10000KG (22046lb)
Lifting Height	1700mm (67in)
Counter top width	650mm (26in)
Counter top width (Optional)	700mm (28in)
Equipment length	6800mm (268in)
Equipment length (Optional)	6000mm (236in)
Rise time	<110s
Descending time	<110s
Pump station pressure	16Mpa
Motor power	3.0kw
Working voltage	380v

- Simple operation, stable operation, low noise, and strong applicability.
- Chain breakage safety device.
- The body is made of welded steel, with exquisite material selection, novel design, and durability.
- Hydraulic transmission type car lift.
- This machine is suitable for lifting all types of buses and trucks, and can lift the car to the required height for various repairs, maintenance, or cleaning operations.
- The chain fracture safety device adopts a manual card plate structure to ensure the safety of personnel, equipment, and vehicles.

## ELEVADOR PARA CARROS DE QUATRO PILARES

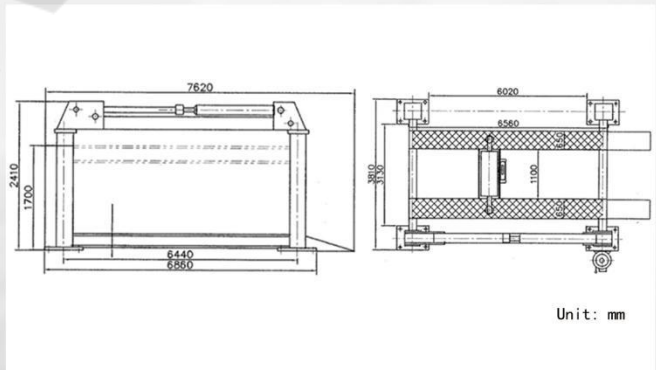

Technical Parameters	
Model no.	JL460-12.0/JL460-15.0/JL-20.0
lifting capacity (Optional)	12000KG (26455lb) / 15000KG (33069lb) / 20000KG (44092lb)
Lifting Height	1700mm (67in)
Rise time	<110s
Descending time	<110s
Equipment length	6800mm (268in)
Equipment length (Optional)	6000mm (236in)
Counter top width	650mm (26in)
Counter top width (Optional)	700mm (28in) / 750mm (30in)
Equipment weight	3810mm (150in)
Equipment height	2410mm (95in)
Pump station pressure	16Mpa
Motor power	2.2kw/3.0kw
Working voltage	380v

- Chain breakage safety device.
- Simple operation, stable operation, low noise, and strong applicability.
- Adapted to four-wheel positioning, equipped with a secondary lifting device, which can be reversed through the manual reversing valve of the pump station to achieve secondary lifting and lowering.
- It is suitable for the vehicle lifting of buses and trucks, and it can be used for a variety of repair, maintenance or cleaning operations when it is lifted to the required working height.

## FOUR POST CAR LIFT

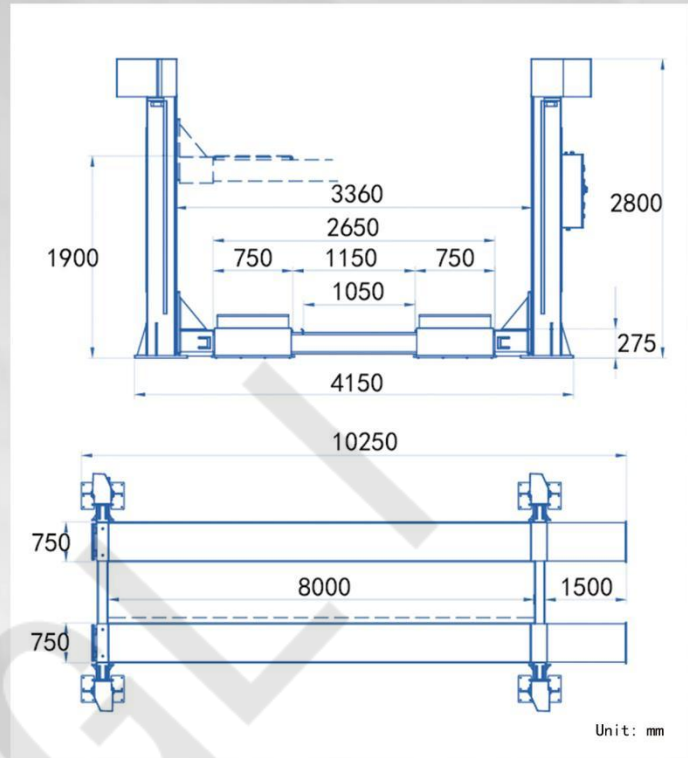

### Technical Parameters

Model no.	JL460-20.1
Lifting weight	20000KG (440921b)
Counter surface width	750mm (3in)
Runway spacing	1150mm (45in)
Lifting height	1900mm (75in)
Landing height	275mm (11in)
Column height	2800mm (110in)
Counter surface length	8000mm (315in)
Inner width of column	3360mm (132in)
Power	4x2.6KW
Power supply voltage	400V · 50HZ

## TRUCK LIFT

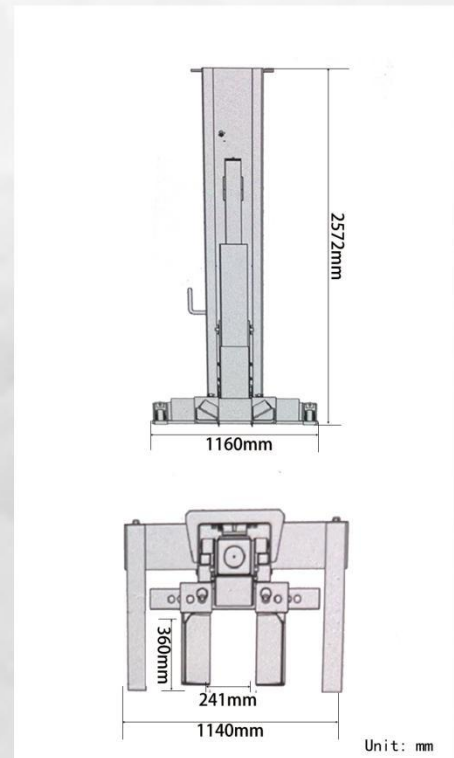

### Technical Parameters

Model no.	JL-8.01
A single column lifts the weight	8165kg (180001b)
Complete set	Optional a set of 2pcs (or 4pcs/6pcs)
Height of column	2572mm (101in)
Height of lift	1889mm (74in)
Width of equipment	1160mm (45.7in)
Length of fork	360mm (14in)
Length of base	1206mm (47in)
Minimum lift fork spacing	241mm (9in)
Maximum lift fork spacing	576mm (22.7in)
Single column weight	657kg (14481b)
Voltage voltage	208-240v 50/60Hz 3-phase electricity

## TRUCK LIFT

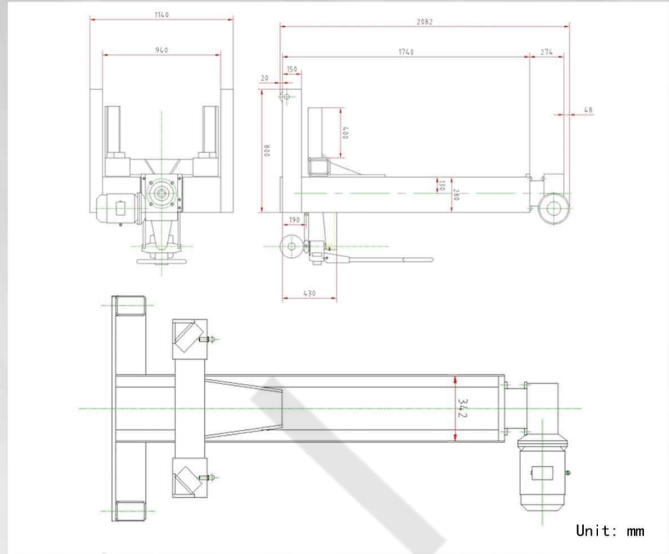

### Technical Parameters

Model no.	JL-2. 51	JL-5. 01	JL-7. 51	JL-10. 01
Single-column lifting weight	2500kg (5512lb)	5000kg (11023lb)	7500kg (16535lb)	10000kg (22046lb)
Complete set	Optional a set of 2pcs (or 4pcs/6pcs)	Optional a set of 2pcs (or 4pcs/6pcs)	Optional a set of 2pcs (or 4pcs/6pcs)	Optional a set of 2pcs (or 4pcs/6pcs)
Lift height	1500mm (59 in)	1500mm (59 in)	1500mm (59 in)	1500mm (59 in)
Output speed	50 (r/min)	50 (r/min)	50 (r/min)	50 (r/min)
Acceleration rate	600 (mm/min)	600 (mm/min)	600 (mm/min)	600 (mm/min)
Motor power	4*1.5kw	4*2.2kw	4*3kw	4*4kw
Power supply voltage	380v	380v	380v	380v

## TRUCK LIFT



### Technical Parameters

Model no.	JL-3. 02	JL-5. 02
Single-column lifting weight	3000kg (6614lb)	5000kg (11023lb)
Complete set	Optional a set of 2pcs (or 4pcs/6pcs)	Optional a set of 2pcs (or 4pcs/6pcs)
Lift height	1500mm (59 in)	1500mm (59 in)
Communication method	Radio	Radio
Acceleration rate	75s	75s
Motor power	4*2kw	4*2.2kw
Power supply voltage	380v	380v

### Technical Parameters

Model no.	JL-7. 52
Single-column lifting weight	7500kg (16535lb)
Complete set	Optional a set of 2pcs (or 4pcs/6pcs)
Lift height	1500mm (59 in)
Communication method	Hydraulic drive
Work stress	16Mpa
Motor power	4*2.2kw
Power supply voltage	380v

## TRUCK LIFT



Technical Parameters	
Model no.	JL-10.02
Single-column lifting weight	10000kg (22046lb)
Complete set	Optional a set of 2pcs (or 4pcs/6pcs)
Lift height	1500mm (59in)
Driving method	Hydraulic drive
Pump station pressure	16Mpa
Motor power	4*3kw
Power supply voltage	380v

### 3D WHEEL ALIGNMENT MACHINE MODEL NO.: S5



Item of measurement	Accuracy	Scope
Total anterior tract	±0.01°	±40°
Angle of inclination	±0.01°	±45°
Angle of back dip	±0.02°	±45°
Angle of interior	±0.02°	±45°
Angle of thrust	±0.01°	±40°
Angle of retreat	±0.01°	±40°
Angle of steering	±0.02°	±50°
Wheel base	±2mm	1219-2438mm
Wheel base	±2mm	2006-4572mm



Beam assembly \*1



Brand computer host \*1



ACDC\*1



LCD monitor \*1



Corner plate \*2

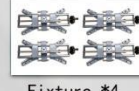

Fixture \*4



Target (front)\*2



Target (rear)\*2



Retainer \*1



Brake retainer \*1



Thrust block \*2



Transition block \*2

#### »»» HARDWARE CONFIGURATION

1. Industrial camera, 2. Target disk, 3. Brand host, 4. Integrated cabinet, 5. 24 inch display, 6. Hanger, 7. Retainer, 8. Brake retainer, 9. Wedge pad, 10. Corner disc, 11. Corner disc transition block

#### »»» EXTEND THE FUNCTION

Shaft offset measurement, wheel offset measurement, single wheel measurement, steering wheel adjustment function, vehicle lift measurement

#### »»» PRODUCT FEATURES

3D measurement technology: body measurement technology, more accurate, stable.

Camera measuring system: dual cameras combined with 4 target disks.

Target disk: traditional electronic sensor to eliminate circuit faults that may be caused by the circuit.

Software system: 60 frames per second, 5 seconds to complete the calculation.

Maintenance: maintenance is simple and easy.

### 3D WHEEL ALIGNMENT MACHINE MODEL NO.: S5 PLUS



Item of measurement	Accuracy	Scope
Total anterior tract	±0.01°	±40°
Angle of inclination	±0.01°	±45°
Angle of back dip	±0.02°	±45°
Angle of interior	±0.02°	±45°
Angle of thrust	±0.01°	±40°
Angle of retreat	±0.01°	±40°
Angle of steering	±0.02°	±50°
Wheel base	±2mm	1219-2438mm



Beam assembly \*1



Brand computer host \*1



ACDC\*1



LCD monitor \*2



Corner plate \*2



Fixture \*4



Target (front)\*2



Target (rear)\*2



Retainer \*1



Brake retainer \*1



Thrust block \*2



Transition block \*2

#### »»» HARDWARE CONFIGURATION

1. Industrial camera, 2. Target disk, 3. Brand host, 4. Integrated cabinet, 5. 32+19 inch display, 6. Hanger, 7. Retainer, 8. Brake retainer, 9. Wedge pad, 10. Corner disc, 11. Corner disc transition block

#### »»» EXTEND THE FUNCTION

Shaft offset measurement, wheel offset measurement, single wheel measurement, steering wheel adjustment function, vehicle lift measurement

#### »»» PRODUCT FEATURES

3D measurement technology: body measurement technology, more accurate, stable.

Camera measuring system: dual cameras combined with 4 target disks.

Target disk: traditional electronic sensor to eliminate circuit faults that may be caused by the circuit.

Software system: 60 frames per second, 5 seconds to complete the calculation.

### 3D WHEEL ALIGNMENT MACHINE MODEL NO.: S6



Item of measurement	Accuracy	Scope
Total anterior tract	±0.01°	±40°
Angle of inclination	±0.01°	±45°
Angle of back dip	±0.02°	±45°
Angle of interior	±0.02°	±45°
Angle of thrust	±0.01°	±40°
Angle of retreat	±0.01°	±40°
Angle of steering	±0.02°	±50°
Wheel base	±2mm	1219-2438mm
Wheel base	±2mm	2006-4572mm



Beam assembly \*1



Brand computer host \*1



ACDC\*1



LCD monitor \*1



Corner plate \*2



Fixture \*4



Target (front) \*2



Target (rear) \*2



Retainer \*1



Brake retainer \*1



Thrust block \*2



Transition block \*2

#### »»» HARDWARE CONFIGURATION

1. Industrial camera, 2. Target disk, 3. Brand host, 4. Integrated cabinet, 5. 32 inch display, 6. Hanger, 7. Retainer, 8. Brake retainer, 9. Wedge pad, 10. Corner disc, 11. Corner disc transition block

#### »»» EXTEND THE FUNCTION

Shaft offset measurement, wheel offset measurement, single wheel measurement, steering wheel adjustment function, vehicle lift measurement

#### »»» PRODUCT FEATURES

3D measurement technology: body measurement technology, more accurate, stable.

Camera measuring system: dual cameras combined with 4 target disks.

Target disk: traditional electronic sensor to eliminate circuit faults that may be caused by the circuit.

Software system: 60 frames per second, 5 seconds to complete the calculation.

Maintenance: maintenance is simple and easy.

### 3D WHEEL ALIGNMENT MACHINE MODEL NO.: S7



Item of measurement	Accuracy	Scope
Total anterior tract	±0.01°	±40°
Angle of inclination	±0.01°	±45°
Angle of back dip	±0.02°	±45°
Angle of interior	±0.02°	±45°
Angle of thrust	±0.01°	±40°
Angle of retreat	±0.01°	±40°
Angle of steering	±0.02°	±50°
Wheel base	±2mm	1219-2438mm
Wheel base	±2mm	2006-4572mm



Beam assembly \*1



Brand computer host \*1



ACDC\*1



LCD monitor \*1



Corner plate \*2



Fixture \*4

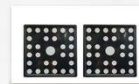

Target (front) \*2



Target (rear) \*2



Retainer \*1



Brake retainer \*1



Thrust block \*2



Transition block \*2

#### »»» HARDWARE CONFIGURATION

1. Industrial camera, 2. Target disk, 3. Brand host, 4. Mobile cabinet, 5. 32 inch display, 6. Hanger, 7. Retainer, 8. Brake retainer, 9. Wedge pad, 10. Corner disc, 11. Corner disc transition block

#### »»» EXTEND THE FUNCTION

Shaft offset measurement, wheel offset measurement, single wheel measurement, steering wheel adjustment function, vehicle lift measurement

#### »»» PRODUCT FEATURES

3D measurement technology: body measurement technology, more accurate, stable.

Camera measuring system: dual cameras combined with 4 target disks.

Target disk: traditional electronic sensor to eliminate circuit faults that may be caused by the circuit.

Software system: 60 frames per second, 5 seconds to complete the calculation.

Maintenance: maintenance is simple and easy.

### 3D WHEEL ALIGNMENT MACHINE MODEL NO.: S8



Item of measurement	Accuracy	Scope
Total anterior tract	$\pm 0.01^\circ$	$\pm 40^\circ$
Angle of inclination	$\pm 0.01^\circ$	$\pm 45^\circ$
Angle of back dip	$\pm 0.02^\circ$	$\pm 45^\circ$
Angle of interior	$\pm 0.02^\circ$	$\pm 45^\circ$
Angle of thrust	$\pm 0.01^\circ$	$\pm 40^\circ$
Angle of retreat	$\pm 0.01^\circ$	$\pm 40^\circ$
Angle of steering	$\pm 0.02^\circ$	$\pm 50^\circ$
Wheel base	$\pm 2\text{mm}$	1219-2438mm
Wheel base	$\pm 2\text{mm}$	2006-4572mm



Beam assembly \*1



Brand computer host \*1



ACDC\*1



LCD monitor \*2



Corner plate \*2



Fixture \*4



Target (front) \*2



Target (rear) \*2



Retainer \*1



Brake retainer \*1



Thrust block \*2



Transition block \*2

#### »»» HARDWARE CONFIGURATION

1. Industrial camera, 2. Target disk, 3. Brand host, 4. Integrated cabinet, 5. 32+19 inch display, 6. Hanger, 7. Retainer, 8. Brake retainer, 9. Wedge pad, 10. Corner disc, 11. Corner disc transition

#### »»» EXTEND THE FUNCTION

Shaft offset measurement, wheel offset measurement, single wheel measurement, steering wheel adjustment function, vehicle lift measurement

#### »»» PRODUCT FEATURES

3D measurement technology: body measurement technology, more accurate, stable.

Camera measuring system: dual cameras combined with 4 target disks.

Target disk: traditional electronic sensor to eliminate circuit faults that may be caused by the circuit.

Software system: 60 frames per second, 5 seconds to complete the calculation.

Maintenance: maintenance is simple and easy.

### 3D WHEEL ALIGNMENT MACHINE MODEL NO.: S9



Item of measurement	Accuracy	Scope
Total anterior tract	$\pm 0.01^\circ$	$\pm 40^\circ$
Angle of inclination	$\pm 0.01^\circ$	$\pm 45^\circ$
Angle of back dip	$\pm 0.02^\circ$	$\pm 45^\circ$
Angle of interior	$\pm 0.02^\circ$	$\pm 45^\circ$
Angle of thrust	$\pm 0.01^\circ$	$\pm 40^\circ$
Angle of retreat	$\pm 0.01^\circ$	$\pm 40^\circ$
Angle of steering	$\pm 0.02^\circ$	$\pm 50^\circ$
Wheel base	$\pm 2\text{mm}$	1219-2438mm
Wheel base	$\pm 2\text{mm}$	2006-4572mm



Beam assembly \*1



Brand computer host \*1



ACDC\*1



LCD monitor \*2



Corner plate \*2



Fixture \*4



Target (front) \*2



Target (rear) \*2



Retainer \*1



Brake retainer \*1



Thrust block \*2



Transition block \*2

#### »»» HARDWARE CONFIGURATION

1. Industrial camera, 2. Target disk, 3. Brand host, 4. Mobile cabinet, 5. 32+19 inch display, 6. Hanger, 7. Retainer, 8. Brake retainer, 9. Wedge pad, 10. Corner disc, 11. Corner disc transition

#### »»» EXTEND THE FUNCTION

Shaft offset measurement, wheel offset measurement, single wheel measurement, steering wheel adjustment function, vehicle lift measurement

#### »»» PRODUCT FEATURES

3D measurement technology: body measurement technology, more accurate, stable.

Camera measuring system: dual cameras combined with 4 target disks.

Target disk: traditional electronic sensor to eliminate circuit faults that may be caused by the circuit.

Software system: 60 frames per second, 5 seconds to complete the calculation.

Maintenance: maintenance is simple and easy.

### 3D WHEEL ALIGNMENT MACHINE (MOVEMENT OF BEAM) MODEL NO.: S6-A



Item of measurement	Accuracy	Scope
Total anterior tract	±0.01°	±40°
Angle of inclination	±0.01°	±45°
Angle of back dip	±0.02°	±45°
Angle of interior	±0.02°	±45°
Angle of thrust	±0.01°	±40°
Angle of retreat	±0.01°	±40°
Angle of steering	±0.02°	±50°
Wheel base	±2mm	1219-2438mm
Wheel base	±2mm	2006-4572mm



#### »»» HARDWARE CONFIGURATION

1. Industrial camera, 2. Target disk, 3. Brand host, 4. Integrated cabinet, 5. 32 inch display, 6. Hanger, 7. Retainer, 8. Brake retainer, 9. Wedge pad, 10. Corner disc, 11. Corner disc transition block

#### »»» EXTEND THE FUNCTION

Shaft offset measurement, wheel offset measurement, single wheel measurement, steering wheel adjustment function, vehicle lift measurement

#### »»» PRODUCT FEATURES

3D measurement technology: body measurement technology, more accurate, stable.

Camera measuring system: dual cameras combined with 4 target disks.

Target disk: traditional electronic sensor to eliminate circuit faults that may be caused by the circuit.

Software system: 60 frames per second, 5 seconds to complete the calculation.

Maintenance: maintenance is simple and easy.

### 3D WHEEL ALIGNMENT MACHINE (MOVEMENT OF BEAM) MODEL NO.: S7-A



Item of measurement	Accuracy	Scope
Total anterior tract	±0.01°	±40°
Angle of inclination	±0.01°	±45°
Angle of back dip	±0.02°	±45°
Angle of interior	±0.02°	±45°
Angle of thrust	±0.01°	±40°
Angle of retreat	±0.01°	±40°
Angle of steering	±0.02°	±50°
Wheel base	±2mm	1219-2438mm
Wheel base	±2mm	2006-4572mm

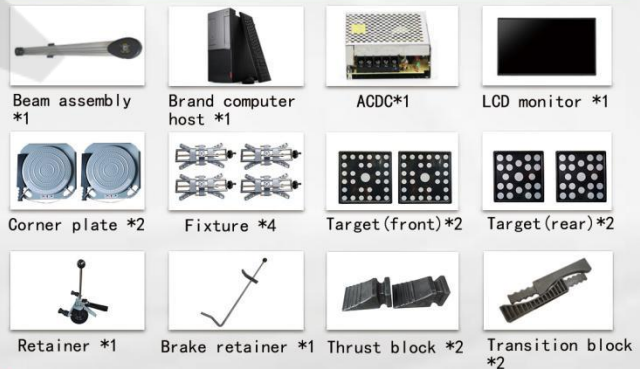

#### »»» HARDWARE CONFIGURATION

1. Industrial camera, 2. Target disk, 3. Brand host, 4. Mobile cabinet, 5. 32 inch display, 6. Hanger, 7. Retainer, 8. Brake retainer, 9. Wedge pad, 10. Corner disc, 11. Corner disc transition block

#### »»» EXTEND THE FUNCTION

Shaft offset measurement, wheel offset measurement, single wheel measurement, steering wheel adjustment function, vehicle lift measurement

#### »»» PRODUCT FEATURES

3D measurement technology: body measurement technology, more accurate, stable.

Camera measuring system: dual cameras combined with 4 target disks.

Target disk: traditional electronic sensor to eliminate circuit faults that may be caused by the circuit.

Software system: 60 frames per second, 5 seconds to complete the calculation.

Maintenance: maintenance is simple and easy.

### 3D WHEEL ALIGNMENT MACHINE (BEAM MOVING MONEY) MODEL NO.: S8-A

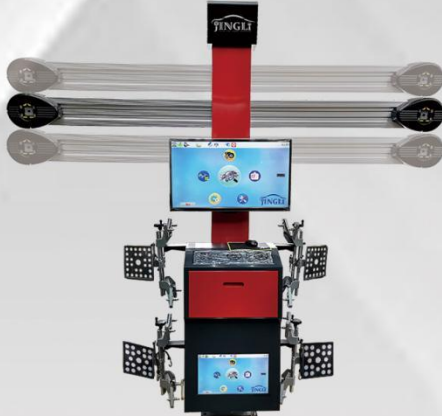

Item of measurement	Accuracy	Scope
Total anterior tract	±0.01°	±40°
Angle of inclination	±0.01°	±45°
Angle of back dip	±0.02°	±45°
Angle of interior	±0.02°	±45°
Angle of thrust	±0.01°	±40°
Angle of retreat	±0.01°	±40°
Angle of steering	±0.02°	±50°
Wheel base	±2mm	1219-2438mm
Wheel base	±2mm	2006-4572mm

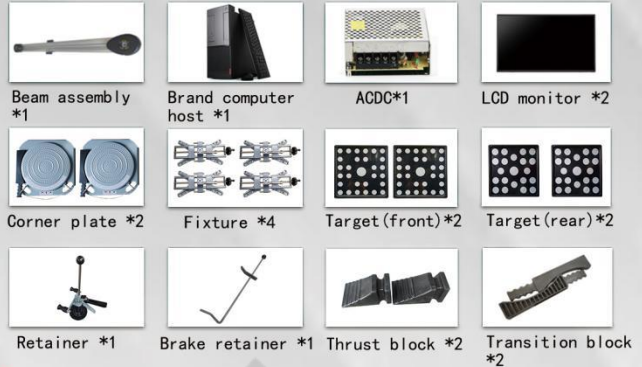

#### »»» HARDWARE CONFIGURATION

1. Industrial camera, 2. Target disk, 3. Brand host, 4. Integrated cabinet, 5. 32+19 inch display, 6. Hanger, 7. Retainer, 8. Brake retainer, 9. Wedge pad, 10. Corner disc, 11. Corner disc transition

#### »»» EXTEND THE FUNCTION

Shaft offset measurement, wheel offset measurement, single wheel measurement, steering wheel adjustment function, vehicle lift measurement

#### »»» PRODUCT FEATURES

3D measurement technology: body measurement technology, more accurate, stable.

Camera measuring system: dual cameras combined with 4 target disks.

Target disk: traditional electronic sensor to eliminate circuit faults that may be caused by the circuit.

Software system: 60 frames per second, 5 seconds to complete the calculation.

Maintenance: maintenance is simple and easy.

### 3D WHEEL ALIGNMENT MACHINE (BEAM MOVING MONEY) MODEL NO.: S9-A



Item of measurement	Accuracy	Scope
Total anterior tract	±0.01°	±40°
Angle of inclination	±0.01°	±45°
Angle of back dip	±0.02°	±45°
Angle of interior	±0.02°	±45°
Angle of thrust	±0.01°	±40°
Angle of retreat	±0.01°	±40°
Angle of steering	±0.02°	±50°
Wheel base	±2mm	1219-2438mm
Wheel base	±2mm	2006-4572mm

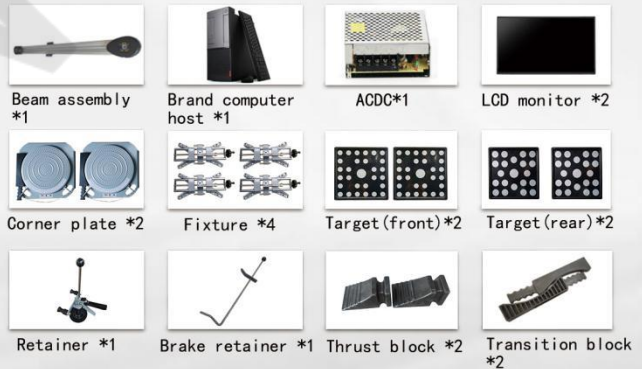

#### »»» HARDWARE CONFIGURATION

1. Industrial camera, 2. Target disk, 3. Brand host, 4. Mobile cabinet, 5. 32+19 inch display, 6. Hanger, 7. Retainer, 8. Brake retainer, 9. Wedge pad, 10. Corner disc, 11. Corner disc transition block

#### »»» EXTEND THE FUNCTION

Shaft offset measurement, wheel offset measurement, single wheel measurement, steering wheel adjustment function, vehicle lift measurement

#### »»» PRODUCT FEATURES

3D measurement technology: body measurement technology, more accurate, stable.

Camera measuring system: dual cameras combined with 4 target disks.

Target disk: traditional electronic sensor to eliminate circuit faults that may be caused by the circuit.

Software system: 60 frames per second, 5 seconds to complete the calculation.

Maintenance: maintenance is simple and easy.

## TIRE CHANGER AD311

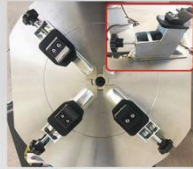

optional:  
motorbike wheel adaptor

### Technical parameters

Model no.	AD311
Outer clamping wheel rim	10" -18"
Inner supporting wheel rim	12" -20"
Maximum wheel diameter	960mm(38")
Maximum wheel width	3" -12"
Operating pressure	6-8 bar
Motor power	380v/750w 220v/1100w
Noise	<70db
Package size	1015*685*1210mm(40*27*48")



Widen the opening and closing Angle of tire shovel arm



Tripod separated aluminum alloy foot assembly



Optional motorcycle fixture



Cast steel bird head



Aluminum shell cylinder, no rust



The oil-water separator is made of aluminum alloy, which is durable

- Pure copper silent motor.
- Cast steel bird head.
- Three aluminum feet.
- The oil-water separator is made of aluminum alloy, which is durable.
- Aluminum shell cylinder, no rust.
- Swing arm disassembly structure, economic, durable.
- Valve stem of air exchange valve is made of stainless steel.
- Big shovel.
- The box adopts the design of the back cover to prevent noise reduction and effectively extend the service life of the turbine and motor.
- Scope of use.
- Optional motorcycle jig.

## SINGLE SWING ARM LOCKING TIRE SCRAPING MACHINE AD312



optional:  
motorbike wheel adaptor

### Technical Parameters

Model no.	AD312
Outer clamping wheel rim	12" -22"
Inner supporting wheel rim	13" -24"
Maximum wheel diameter	1040mm(41")
Maximum wheel width	3" -15"
Operating pressure	8-10bat
Motor power	110v/220v/380v
Tire pressure	3000kg(6614lb)
Noise	<70db
Outer packing size	1100*900*800mm(43*35*31")



Swing arm rotation axis



Optional tire pressure rod

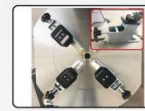

Optional motorcycle fixture



Cast steel bird head



Universal shovel



Explosion-proof export standard oil-water separator

- Swing arm rotation axis.
- New generation of external locking system.
- Cast steel bird head.
- Lengthen and adjust the six-square sleeve.
- Aluminum shell cylinder, no rust.
- Thickener plate, long-term use, no deformation, more safe and durable.
- Universal shovel.
- Explosion-proof export standard oil-water separator.
- Five foot pedal.
- Pure copper silent motor.
- Scope of use: tire scraping motorcycle, electric car, car, off-road vehicle.

## PNEUMATIC LEFT AUXILIARY ARM DOUBLE ROLLER TIRE SCRAPER AD416



### Technical Parameters

Model no.	AD416
Outer clamping wheel rim	12" -22"
Inner supporting wheel rim	13" -24"
Maximum wheel diameter	1040mm (41")
Maximum wheel width	3" -15"
Operating pressure	8-10bat
Power voltage	110v/220v/380v
Tire pressure	3000kg (6614lb)
Noise	<70db
Package size	1200*920*900mm (47*36*35")

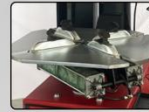

The thickness is 15mm thick with scale square plate.



The cylinder is 370 long, and the pipe joint is copper.



High light metal bird head.



Laser cutting integrated extension shovel tire arm.



Explosion-proof export standard oil-water separator.



Thicken and thicken the connecting shaft of the auxiliary arm.

- Trapezoidal thickened steel plate is bent and connected with the top of the column.
- Trinity auxiliary arm.
- The auxiliary arm pipe adopts imported flame retardant nylon network tube.
- Auxiliary arm connecting shaft thick and thick.
- Press and lock.
- Nylon double pressure tire wheel, strong and durable internal skeleton structure, down 25° roller pressure tire.
- Column and box integrated connection.
- Thickness of 13mm thick with scale square plate.
- Spline gear shaping turbine box and large plate.
- Universal shovel arbitrarily s with Angle shovel tire, laser cutting integrated extension shovel tire arm.
- Five feet, strong and durable.
- Explosion-proof oil-water separator.

## RIGHT CYLINDER ASSISTED ARM TIRE SCRAPER AD411



### Technical Parameters

Model no.	AD411
Outer clamping wheel rim	10" -22"
Inner supporting wheel rim	12" -24"
Maximum wheel diameter	1040mm (41")
Maximum wheel width	3" -15"
Operating pressure	8-10bat
Power voltage	220v/380v
Motor power	0.75kw/1.1kw
Tire pressure	3000kg (6614lb)
Noise	<70db
Package size	1150*900*850mm (45*35*33")



Mechanical pressure tire

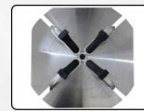

Thickened scale square plate



Export standard cylinder



Export type bird head



Universal shovel switch Angle shovel tire



Oil water separator

- Pneumatic switch controls the auxiliary arm.
- The six-square bar adopts pneumatic locking function.
- The auxiliary arm adopts the function of separating and locking bits.
- Turbine box and large plate, spline gear shaping turbine box and.
- Export type bird head, durable without deformation.
- Column and box integrated connection.
- Extended and adjustable six-square sleeve.
- Thickness of 13mm thick with scale square plate.
- Spline gear shaping turbine box and large plate.
- Universal shovel arbitrarily switch Angle shovel tire, laser cutting integrated extension shovel tire arm.
- Classic five-foot pedal, strong and durable.
- Export standard oil-water separator.

## DOUBLE AIR LOCK DOUBLE AUXILIARY ARM TIRE SCRAPER AD412



Technical Parameters	
Model no.	AD412
Outer clamping wheel rim	12" -22"
Inner supporting wheel rim	13" -24"
Maximum wheel diameter	1040mm (41")
Maximum wheel width	3" -15"
Operating pressure	8-10bat
Power voltage	220v/380v/110v
Motor power	0.75kw/1.1kw
Tire pressure	3000kg (6614lb)
Noise	<70db
Package size	1170*870*900mm (46*34*35")



Any rotation, more accurate tire pressure Angle



The cylinder and trachea joints are copper joints



Classic pedal, tire scraper internal switch control system



Universal shovel freely switch Angle shovel tire



Thickened scale square plate



Export standard oil-water separator

- Dual pneumatic switch to control two auxiliary arms.
- The six-square bar adopts pneumatic locking function.
- The right auxiliary arm adopts the separation and locking function.
- Right hand tire pressure wheel, 360° arbitrary rotation.
- Left mechanical hand tire pressure head, tire pressure two in one function, when pressing the tire to follow its rotation, to avoid the tire mouth stuck at the edge of the hub.
- Column and box integrated connection.
- Export standard cylinder.
- Large scale plate.
- Universal shovel freely switch Angle shovel tire.
- Standard oil-water separator.
- Extended and adjustable six-square sleeve.

## THREE - POINT PRESSURE TIRE REARLEANING AUXILIARY ARM TIRE SCRAPING MACHINE AD418



Technical Parameters	
Model no.	AD418
Outer clamping wheel rim	10" -22"
Inner supporting wheel rim	12" -24"
Maximum wheel diameter	1040mm (41")
Maximum wheel width	3" -15"
Power voltage	110v/220v/380v
Tire pressure	3200kg (7055lb)
Noise	<70db
Package size	1200*920*1720mm (47*36*68")



Pneumatic locking



Hexagonal set



Widen the opening and closing Angle of tire shovel arm



Auxiliary arm pressure tire wheel



Three point pressure tire auxiliary arm



Thicken chrome plate

- The large cylinder adopts all-aluminum alloy single exhaust spring type large cylinder.
- Pure copper silent motor, sufficient power, low noise.
- Turbine box, spline gear shaping turbine box to ensure stable operation of the large plate.
- Export type white steel bird head.
- Three point pressure tire auxiliary arm.
- Large plate thick chrome plate, tire scraping strong deformation.
- Export standard cylinder, tensile strength is better, corrosion resistance is not rust.
- Multi-function telescopic adjusting pressure tire.
- The arm pipe adopts imported flame retardant nylon network tube.
- Universal shovel arbitrarily switch Angle shovel tire, laser cutting integrated extension shovel tire arm.
- Explosion-proof export standard oil-water separator.

## AUTOMATIC DETACHABLE 24 INCH TIRE SCRAPER AD616Q



Technical Parameters	
Model no.	AD616Q
Applicable rim	12"-24"
Max wheel diameter	980mm (39")
Max tire width	12"
Working pressure	8-10bar
Power voltage	380V/220V/110V
Motor power	0.75KW/1.1KW
Equipment size	1600×1450×1870mm (63*57*74")
Package size	1220×950×1710mm (48*37*67")



The spindle is precisely fixed



Bold fixed bracket



Turning over frame



Turning bird's head



Tire pressure device



Mostly easy separation for adjustment

- New reversing tire head structure, work without prying bar, add plastic protective cover, double protection hub from injury.
- S41 bold six-square bar, better strength, reduce the deformation in the process of tire removal.
- Equipped with manipulator, make the disassembly and installation of hard wall flat tire more time saving, labor-saving, simple and quick operation.
- The mechanical arm is in the form of a suit, and the internal polymer plastic block is used as a wear-resistant slider, and the mechanical arm runs smoothly and freely.
- Structure design is novel and generous, easy to use and flexible.

## FULLY AUTOMATIC DETACHABLE 27 INCH TIRE SCRAPER AD618Q



Technical Parameters	
Model no.	AD618Q
Applicable rim	13"-27"
Max wheel diameter	1120mm (44")
Max tire width	12"
Working pressure	8-10bar
Power voltage	380V/220V/110V
Motor power	0.75KW/1.1KW
Equipment size	1170×1120×1850mm (46*44*73")
Package size	1180×1130×1870mm (46*44*74")



The spindle is precisely fixed



Bold fixed bracket



Turning over frame



Turning bird's head



Tire pressure device



Mostly easy separation for adjustment

- New reversing tire head structure, work without prying bar, add plastic protective cover, double protection hub from injury.
- S41 bold six-square bar, better strength, reduce the deformation in the tire removal process.
- Equipped with manipulator, make the disassembly and installation of hard wall flat tire more time saving, labor-saving, simple and quick operation.
- The nylon plate on the tire seat does not hurt the rim, suitable for the installation of various tires.
- The mechanical arm is in the form of a suit, and the internal polymer plastic block is used as a wear-resistant slider, and the mechanical arm runs smoothly and freely.

## FULLY AUTOMATIC CROWBAR FREE TIRE SCRAPER AD516



Technical Parameters	
Model no.	AD516
Outer clamping wheel rim	10" -22"
Inner supporting wheel rim	12" -24"
Maximum wheel diameter	1040mm (41")
Maximum wheel width	3" -15"
Power voltage	220v/380v
Operating pressure	0.8-1.0mpa
Tire pressure	3000kg (6614lb)
Noise	<70db
Package size	1200*1000*1800mm (47*39*71")



- The large cylinder adopts all-aluminum alloy single exhaust spring type large cylinder.
- Pure copper silent motor, sufficient power, low noise.
- Turbine box, spline gear shaping turbine box to ensure stable operation of the large plate.
- Export type white steel bird head.
- Three point pressure tire auxiliary arm.
- Large 15mm thick chrome plate.
- Export standard cylinder, tensile strength is better.
- Multi-function telescopic adjusting pressure tire.
- The arm pipe adopts imported flame retardant nylon network tube.
- Universal shovel arbitrarily switch Angle shovel tire, laser cutting integrated extension shovel tire arm.
- Explosion-proof export standard oil-water separator.

## TRUCK TIRE SCRAPER



Technical Parameters	
Model no.	AD1000
Product name	Truck tire scraper
Fit wheel rim	14" -42"
Maximum wheel weight	500kg (1102lb)
Maximum wheel diameter	1500mm (59")
Maximum wheel width	780mm (31")
Stress at work	0-130bar
Power supply	415v/380v/240v/220v/110v
Hydraulic pump power	3.0kw
Weight of equipment	560kg (1234.6lb)

- Full size coverage of tires, large and small car tire scraping machine.
- The mechanical transmission part adopts the hydraulic motor, the oil pipe thickening scheme, so that the hydraulic motor speed faster, more powerful power.
- The closed structure of the gearbox can improve the service life of the gear and prevent the wear of the gearbox caused by entering the magazine.
- With hand and foot, tire removal is more coordinated and efficient.
- The tire pressure wheel can also be adjusted freely in the work, and there are ruler positioning, tire edge positioning, to avoid re-adjusting the position when the tire is on again.
- Break the traditional concept of tire dismantling.
- Full-size coverage of tires, covering light trucks, heavy trucks, small cars and SUVs.

# TIRE CHANGER AD617



Technical Parameters	
Model no.	AD617
Maximum wheel diameter	46.9"
Maximum wheel width:	16.7"
Tire size	10" /30"
Power supply voltage	110/220/380v
Motor power	1.5kw*2
Hydraulic wheel pressure	3000kg (6614lbs)
Air pressure	0.8-1.0mpa 116-145psi
Outer dimensions	1500*980*1600mm (59*39*63" )

- Hydraulic tire remover, both the lifting mechanism and the bird head are hydraulically controlled, which is relatively fast and precise.
- Use hydraulic nose pliers.
- Contains a burst expander.
- Hydraulic tire removal machine - multi-functional auxiliary arm tire removal machine - tire removal machine without the need for a pry bar.
- No damage to the tires, no scraping of the rims, no need for a pry bar. Safe, quick, time-saving and labor-saving. Suitable for large-sized non-standard tires, flat tires and pneumatic tires. A good helper for all these types of tires.

## WHEEL BALANCER AD111



Manual handbrake



Manual tape measure



Standalone display



Balanced spindle

Technical Parameters	
Model no.	AD111
Hub diameter	10" -24"
Hub width	1.5" -10"
Maximum wheel diameter	1000mm (39" )
Maximum wheel weight	70kg (154lb)
Balancing period	7s
Balancing accuracy	±1g
Power supply voltage	12v/220v
Motor	0.25kw
Noise	<20db
Main shaft rotation rate	≤200r/min
Packaging size	835*405*500mm (33*16*20" )

- The bottom of the balance machine case is equipped with a manual brake, which is more convenient to operate.
- The balance machine uses a nylon scale with clear and accurate scales for durable use.
- The balance machine manually inputs data for precise measurement.
- The independent display design achieves a perfect unity of appearance practicality.
- The balance machine can be used in a car, saving space, and the small body has a great effect.

## WHEEL BALANCER AD112



Tool storage cell



Independent display panel



High precision mechanical spindle



Vertebral body placement rod

Technical Parameters	
Model no.	AD112
Circle width	1.5" -16"
Circle diameter	10" -24"
Maximum wheel diameter	1000mm (39" )
Rotation speed	230r/min
Balance accuracy	±1g
Power voltage	220v/50Hz
Motor power	250w
Maximum wheel weight	65kg (143lb)
Equipment size	920*650*1050mm (36*26*41" )
Package size	970*700*1115mm (38*28*44" )
Optional	Laser light (optional)

- With self-correction and self-diagnosis function.
- High precision mechanical spindle: high precision spindle adopts heat treatment process, improve the strength of the spindle, wear resistance has service life.
- Vertebral body placement rod: three vertebral body placement rods are added on the left side of the body to facilitate placement and access of different types of vertebral bodies.
- Tool storage cell: widen and increase the storage cell, easy to place various specifications of balance blocks and tools, easy to access.
- Independent display panel: the operation panel adopts advanced aluminum foaming technology, high frequency keys, strong resilience, easy to understand the operation mode.
- The body base is lengthened: when the body base is lengthened and the balance measurement is increased, the operation is more stable and the data transmission is more accurate.
- Aluminum alloy ruler: accurate measurement of tire

## WHEEL BALANCER AD113



High heat dissipation standard aluminum shell copper wire motor



Operation button panel



High precision transmission spindle



Automatic start and stop tire protection cover

Technical Parameters	
Model no.	AD113
Diameter of wheel hub	10"-24"
Width of wheel hub	1.5"-16"
Maximum wheel diameter	1000mm (39")
Maximum wheel weight	65kg (143lb)
Speed of rotation	200r/min
Accuracy of balance	±1g
Parameters of motor	220v50HZ
Power of motor	250w
Period of equilibrium	7s
Inside pack size	920*650*1050mm (36*26*41")
Size of outsourced	970*700*1115mm (38*28*44")

- Infrared indication assist point finding.
- High heat dissipation standard aluminum shell copper wire motor.
- Automatic start and stop tire protection cover.
- High precision transmission spindle.
- Vertebral body placement rod.
- Multiple storage compartments.
- Operation button panel.
- Dual pneumatic buttons.
- The left side is equipped with convenient storage.
- Track type nylon caliper.
- High precision balancing machine spindle.
- Inside the box body.
- A new generation of high-precision motherboard.
- High heat dissipation standard aluminum shell copper wire motor.

## WHEEL BALANCER AD114



The balancing machine shaft is heat treated



Measuring pull rule



Optional protective cover



Liquid crystal display



Storage box, easy to use



Full range of accessories

Technical Parameters	
Model no.	AD114
Rim diameter	10"-24"
Maximum wheel diameter	950mm (37")
Rim width	1.5"-16"
Maximum wheel weight	65KG (143lb)
Rotational speed	200r/min
Balance accuracy	±1g
Motor power	220V-240V 50/60Hz 250W
Equipment size	1120×900×1550mm (44*35*61")
Package size	985×770×885mm (39*30*35")

- Suitable for all kinds of light vehicle tire precision balance adjustment.
- With automatic dynamic balance, static balance and aluminum rim balance function.
- Advanced sensor, high accuracy of pressure value display.
- Balance machine shaft after heat treatment.
- OPT function, tire and wheel hub optimization combination function.
- Optional protective cover.

## WHEEL BALANCER AD115



Technical Parameters	
Model no.	AD115
Diameter of rotation	10"-24"
Maximum wheel weight	65kg (143lb)
Maximum wheel diameter	1000mm (39")
Width of wheels	1.5"-16"
Speed of rotation	230r/min
Accuracy of balance	±1g
Outer packing size	1100*800*1200mm (43*31*47")
Parameters of motor	110V/220V
Weight	130KG (287lb)



Aluminum alloy automatic drawing ruler



Multiple storage compartments



Laser assisted laser



Key press panel



High definition screen



Optional protective cover

- New generation of high precision motherboard, one-time welding process.
- Multiple storage, can place different grams of balance block, tools, easy to use.
- Lengthen high-precision balancing machine spindle, imported CNC processing technology, to ensure the accuracy of the spindle.
- Operation key panel, motherboard 711 board, stable quality, low failure rate, high frequency key, strong resilience.
- Independent display of numerical panel, beautiful atmosphere, numerical clear and easy to read.
- Thermal standard aluminum shell copper wire motor, shell with heat sink, heat dissipation type is stronger.

## WHEEL BALANCER AD116



Technical Parameters	
Model no.	AD116
Circle width	1.5" -16"
Circle diameter	10" -24"
Maximum wheel diameter	1000mm (39")
Rotation speed	230r/min
Balance accuracy	±1g
Motor parameters	220v/50Hz
Motor power	250w
Maximum wheel weight	65kg (143lb)
Equipment size	850*530*980mm (33*21*39")
Outer package size	1000*700*1200mm (39*28*47")



Pure copper core motor



Display screen



Spindle balance precision is high



Optional protective cover

- Double start switch on key panel.
- Multiple storage compartments.
- 812 Computer board, zero degree difference in secondary calibration.
- High balance accuracy and low noise.
- Laser lamp assist, motor positioning, electromagnetic brake, with infrared laser automatic point finding, motor positioning, electromagnetic brake function.
- The motor has the function of motor fixed point and electromagnetic brake.
- Extend the base, the box is more stable in work, and the transmission data is accurate.
- Thicken the box to ensure the stability of the machine when the tire is running.
- National standard extension power cord.

## AUTOMATIC TIRE BALANCING MACHINE AD117



Lengthen high precision  
balancing machine spindle



Protective cover



Operation button panel

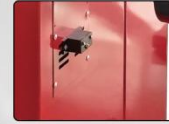

Infrared indicator  
auxiliary point finding

### Technical Parameters

Model no.	AD117
Rim diameter	10"-24"
Maximum wheel diameter	1080mm (43")
Rim width	1.5"-16"
Maximum wheel weight	65kg (143lb)
Rotational speed	≤200r/min
Balance accuracy	±1g
Motor power	110v/220v
Equipment size	1380*920*1660mm (54*36*65")
Package size	1090*730*1200mm (43*29*47")

- Automatic tire balancing machine.
- Aluminum alloy automatic measuring measuring ruler.
- Infrared indicator auxiliary point finding.
- Balance point electromagnetic induction brake.
- Linkage switch tire protection cover.
- Over-birth wave measurement of protective cover.
- Independent display panel.
- Operation button panel.
- Multiple storage.
- Lengthen high-precision balancing machine spindle.
- Vertebral body placement rod.
- The body base is lengthened.
- A new generation of high-precision motherboard.
- Electronic brake fixed point copper wire motor high precision transmission spindle.

## WHEEL BALANCER AD119



Measuring pull rule



Lengthen high precision  
balancing machine spindle



Liquid crystal display



Key panel,  
storage compartment

### Technical Parameters

Model no.	AD119
Wheel diameter	10 "-24"
Rim width	1.5 "-20"
Maximum wheel weight	65kg
Motor power	200W
Power supply	220V/50Hz
Balance accuracy	±1g
Rotation speed	200r/min
Position accuracy	1.5°
Cycle time	8s
Noise	< 70db
Dimensions	960*560*1150mm (38*22*45 ")

- Adopt HD LCD screen, 3D animation interface, intelligent LCD screen dynamic information display, so that all balance mode operation, intuitive and easy to understand.
- A variety of balancing methods can be used to counterweight sticks, fixtures, hidden sticks, etc.
- Automatically enter rim data by measuring scale.
- Intelligent self-calibration, range self-calibration function, self-fault diagnosis and protection function.
- Suitable for all kinds of steel structure, hard aluminum structure rim.

## AUTOMATIC LASER INFRARED FIXED POINT BALANCING MACHINE AD200



Tire lift truck



Big cars and small cars



Liquid crystal display



Storage grid more

### Technical Parameters

Model no.	AD200
Width of wheel hub	1.5"-24"
Diameter of wheel hub	10"-24"
Maximum wheel weight	150kg (331lb)
Maximum wheel diameter	1200mm (47")
Period of equilibrium	7-12s
Spindle speed	≤180r/min
Average accuracy	±1g
Weight of machine	200KG (441lb)
Dimensions of package	1230x900x1430mm (48*35*56")
Stress at work	0.8 Mpa
Power of motor	0.75KW

- Model AD200 top matching version. Large and small car (Max 1200R22.5).
- Equipped with laser infrared fixed point function.
- Equipped with double brake system, foot pneumatic brake system, auxiliary brake system.
- Equipped with pneumatic locking function, automatically lock the position of the lead block.
- Equipped with storage box, can store tools.
- Equipped with tire elevator.
- Equipped with self-calibration function.

## CAR FRAME MACHINE 2.1\*5.6M



OR

Pneumatic/Electrical (optional)

### Technical Parameters

Model no.	JL3500/JL3600
Lifting weight	3500kg (7716lb)
Overall length	5600mm (221in)
Overall width	2100mm (83in)
Runway plate width	500/550mm (20/22in) (optional)
Height of table	560mm (22in)
Hydraulic pressure	70Mpa (10000psi)
Post working range	360°
Lata traction pull	100KN
Thickness of steel plate	10mm up and 10mm down 10mm up and 8mm down
Lifting way	Electrical/pneumatic(optional)



High strength step wheel



Reinforcement vise



Guide ring misplacement loop welding

- Manganese steel material, ten thousand watt laser whole plate cutting.
- The main fixture unique spiral lifting, height can be adjusted.
- Guide ring dislocation ring type welding, chain bold, can pull 10 tons without deformation.
- High strength step wheel, avoid the risk of concave wheel and falling lata, platform track 360° rotation without dead Angle, easy to operate and save effort.
- High temperature dusting treatment, waterproof and rust-proof.
- Pneumatic electric style is optional.

## CAR FRAME MACHINE 2.2\*5.6M



OR

Pneumatic/Electrical (optional)

### Technical Parameters

Model no.	JL3800
Lifting weight	3500kg (7716lb)
Overall length	5600mm (221in)
Overall width	2200mm (87in)
Runway plate width	600mm (24in)
Height of table	560mm (22in)
Hydraulic pressure	70Mpa (10000psi)
Post working range	360°
Lata traction pull	100KN
Thickness of steel plate	10mm up and 10mm down 10mm up and 8mm down
Lifting way	Electrical/pneumatic(optional)



High strength step wheel



Reinforcement vise



Guide ring misplacement loop welding

- Manganese steel material, ten thousand watt laser whole plate cutting.
- The main fixture unique spiral lifting, height can be adjusted.
- Guide ring dislocation ring type welding, chain bold, can pull 10 tons without deformation.
- High strength step wheel, avoid the risk of concave wheel and falling lata, platform track 360° rotation without dead Angle, easy to operate and save effort.
- High temperature dusting treatment, waterproof and rust-proof.
- Pneumatic electric style is optional.

## FIVE HOLES CAR FRAME MACHINE 2.2\*5.6M

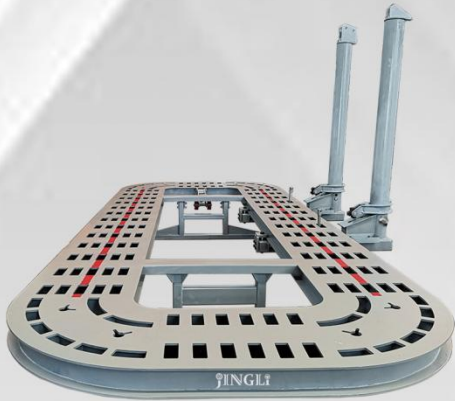

Technical Parameters	
Model no.	JL3900
Lifting weight	3500kg (7716lb)
Overall length	5600mm (221in)
Overall width	2200mm (87in)
Runway plate width	600mm (24in)
Height of table	560mm (22in)
Hydraulic pressure	70Mpa (10000psi)
Post working range	360°
Lata traction pull	100KN
Thickness of steel plate	10mm up and 10mm down 10mm up and 8mm down
Lifting way	Electrical/pneumatic(optional)



High strength step wheel



Reinforcement vise



Guide ring misplacement loop welding



OR  
Pneumatic/Electrical (optional)



- Manganese steel material, ten thousand watt laser whole plate cutting.
- The main fixture unique spiral lifting, height can be adjusted.
- Guide ring dislocation ring type welding, chain bold, can pull 10 tons without deformation.
- High strength step wheel, avoid the risk of concave wheel and falling lata, platform track 360° rotation without dead Angle, easy to operate and save effort.
- High temperature dusting treatment, waterproof and rust-proof.
- Pneumatic electric style is optional.

## CAR FRAME MACHINE WHOLE BENCH MOVE 2.2\*5.8M ELECTRIC



Technical Parameters	
Model no.	JL3900-ZT
Lifting weight	3500kg (7716lb)
Overall length	5800mm (228in)
Overall width	2200mm (87in)
Runway plate width	600mm (24in)
Height of table	330-1200mm (13-47in)
Hydraulic pressure	70Mpa (10000psi)
Post working range	360°
Lata traction pull	100KN
Thickness of steel plate	10mm up and 10mm down
Motor power	220v/380v



High strength step wheel



Reinforcement vise



Powder spraying process



- Power unit three output electric pump station, a remote control independent operation.
- Mesa laser cutting, high flatness, no working tensile blind area.
- The main fixture unique spiral lifting, height can be adjusted arbitrarily.
- Double cylinder hydraulic tilt vertical lifting platform, hydraulic and mechanical lock double insurance.
- Guide ring dislocation ring welding, can pull 10 tons without deformation.
- Step wheel, avoid concave wheel and falling weft risk, platform track 360° rotation without dead Angle.
- High temperature dust removal treatment, waterproof and rust-proof.

## CAR FRAME MACHINE 2.1\*5.6M

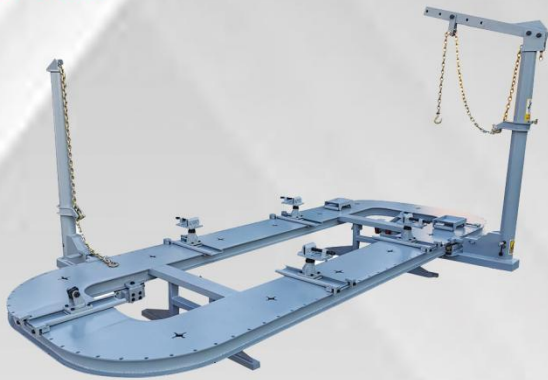

Technical Parameters	
Model no.	JL800/JL900
Lifting weight	3500kg (7716lb)
Overall length	5600mm (221in)
Overall width	2100mm (83in)
Runway plate width	500/550mm (20/22in) (Optional)
Height of table	560mm (22in)
Hydraulic pressure	70Mpa (10000psi)
Post working range	360°
Lata traction pull	100KN
Thickness of steel plate	10mm up and 10mm down
Lifting way	Electrical/pneumatic (optional)



Large size base



Reinforcement vise



Guide ring misplaced loop welding



OR

Pneumatic/Electrical (optional)

- Manganese steel material, ten thousand watt laser whole plate cutting.
- The main fixture unique spiral lifting, height can be adjusted.
- Guide ring dislocation ring type welding, chain bold, can pull 10 tons without deformation.
- High strength step wheel, avoid the risk of concave wheel and falling lata, platform track 360° rotation without dead Angle, easy to operate and save effort.
- High temperature dusting treatment, waterproof and rust-proof.
- Pneumatic electric style is optional.

## CAR FRAME MACHINE 2.2\*5.6M



Technical Parameters	
Model no.	JL1000
Lifting weight	3500kg (7716lb)
Overall length	5600mm (221in)
Overall width	2200mm (87in)
Runway plate width	600mm (24in)
Height of table	560mm (22in)
Hydraulic pressure	70Mpa (10000psi)
Post working range	360°
Lata traction pull	100KN
Thickness of steel plate	10mm up and 10mm down
Lifting way	Electrical/pneumatic (optional)



Large size base



Reinforcement vise



Guide ring misplaced loop welding



OR

Pneumatic/Electrical (optional)

- Manganese steel material, ten thousand watt laser whole plate cutting.
- The main fixture unique spiral lifting, height can be adjusted.
- Guide ring dislocation ring type welding, chain bold, can pull 10 tons without deformation.
- High strength step wheel, avoid the risk of concave wheel and falling lata, platform track 360° rotation without dead Angle, easy to operate and save effort.
- High temperature dusting treatment, waterproof and rust-proof.
- Pneumatic electric style is optional.

## SQUARE TUBE CAR FRAME MACHINE



Technical Parameters	
Model no.	JL-60
Lifting weight	3500kg (7716lb)
Overall length	5200mm (205in)
Overall width	2200 (87in)
Runway plate width	600 (24in)
Height of table	560mm (22in)
Hydraulic pressure	70Mpa (10000psi)
Post working range	360°
Lata traction pull	100KN



Chain of chains



Universal direction wheel



Hydraulic tilting lifting platform

- Manganese steel material, ten thousand watt laser whole plate cutting.
- The main fixture unique spiral lifting, height can be adjusted.
- Guide ring dislocation ring type welding, chain bold, can pull 10 tons without deformation.
- High strength step wheel, avoid the risk of concave wheel and falling lata, platform track 360° rotation without dead Angle, easy to operate and save effort.
- High temperature dusting treatment, waterproof and rust-proof.
- The pneumatic hydraulic pump is powerful and durable.

## I BEAM STEEL CAR FRAME MACHINE



Technical Parameters	
Model no.	JL-56
Lifting weight	3500kg (7716lb)
Overall length	5200mm (205in)
Overall width	2100mm (83in)
Height of table	560mm (22in)
Hydraulic pressure	70Mpa (10000psi)
Post working range	360°
Lata traction pull	100KN

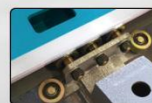

Universal direction wheel



Chain of chains



Hydraulic tilting lifting platform

- Manganese steel material, ten thousand watt laser whole plate cutting.
- The main fixture unique spiral lifting, height can be adjusted.
- Guide ring dislocation ring type welding, chain bold, can pull 10 tons without deformation.
- High strength step wheel, avoid the risk of concave wheel and falling lata, platform track 360° rotation without dead Angle, easy to operate and save effort.
- High temperature dusting treatment, waterproof and rust-proof.

## GOSSIP IN A FLOATING MANNER



Widen the base



45 steel forging chain



Thicken the vise chain

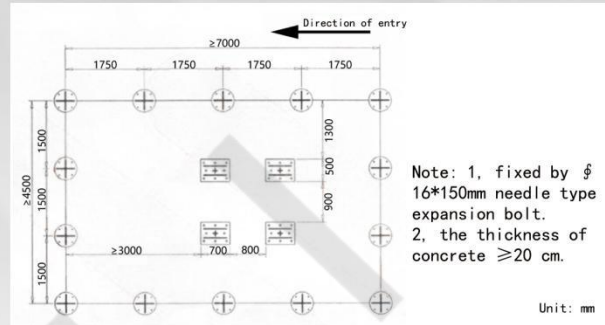

Technical Parameters	
Model no.	JL-A870
Height of main latta	1900mm (75in)
Main latta diameter	140mm (5.5in)
Main latta diameter (Optional)	160mm (6in)
Maximum output of main tower	10000kg (22046lb)
Main tower base	600*600mm (24*24in)
Height of auxiliary latta	2000mm (79in)
Auxiliary latta base	300*300mm (12*12in)

- Power latta three-point support.
- Light latta fixed car, can also cooperate with hydraulic equipment or shouban hoist repair plastic.
- Platform track, the maximum range of length and width adjustment, suitable for various models.
- The main fixture clamp, fast and firm clamping of the model.
- Does not occupy space, can be dismantled, repaired, installed and other operations at the same time.
- Chain retainer for any point of the body deformation correction force direction, no dead Angle, easy to

## GEOSYNCLINAL GROUND GOSSIP

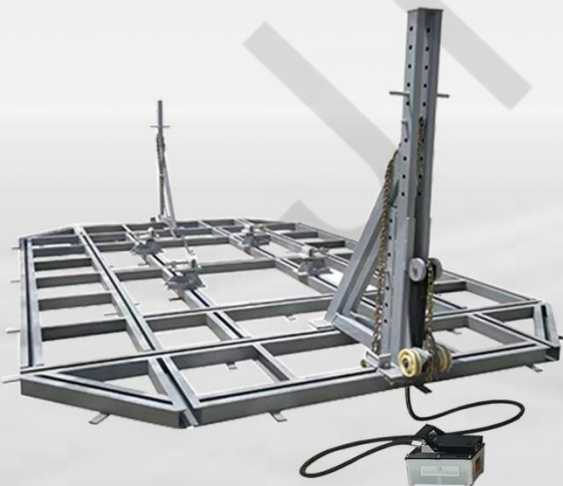

Main latch tower



Stiffened plate vise



Deputy latta

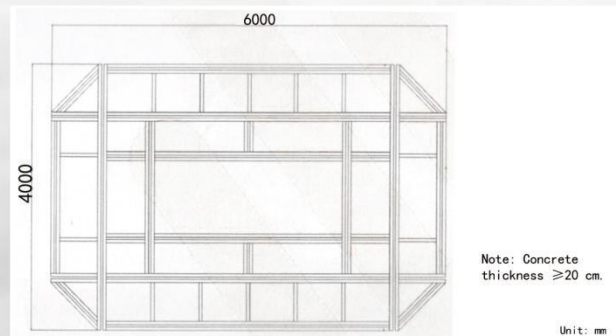

Technical Parameters	
Model no.	JL-A860
Height of main latta	2000mm (79in)
Maximum output of main tower	10000kg (22046lb)
Height of auxiliary latta	1800mm (71in)
Auxiliary latta base	800*400mm (31*16in)
Reservoir frame	5950*4000mm (234*157in)

- Does not occupy the site, easy to operate.
- Efficient and fast, can make each combination station, the accident car one or more places for simultaneous repair.
- Hydraulic system, strong power, durable, convenient maintenance, fast, adequate accessories.
- Precision gear clamp can lock the chassis more firmly, durable.
- Rich rice gold stretching tools, more flexible and convenient to use.
- Channel steel plate GB 14 mm thick.

## ELECTRIC HEATING SPRAY BOOTH X-500



Technical Parameters	
Model no.	X-500
Overall dimension	7000 × 4000 × 3200mm (276*157*126in)
Room size	6900 × 3900 × 2600mm (272*154*102in)
Width of access door	3000mm (118in)
Door height	2500mm (98in)
Power of inlet fan	3*2kw
Exhaust fan power	5.5kw
Fan air volume	10000*2m³/h
Paint baking power	30kw
Wind speed	0.25m/s
Total power	37kw

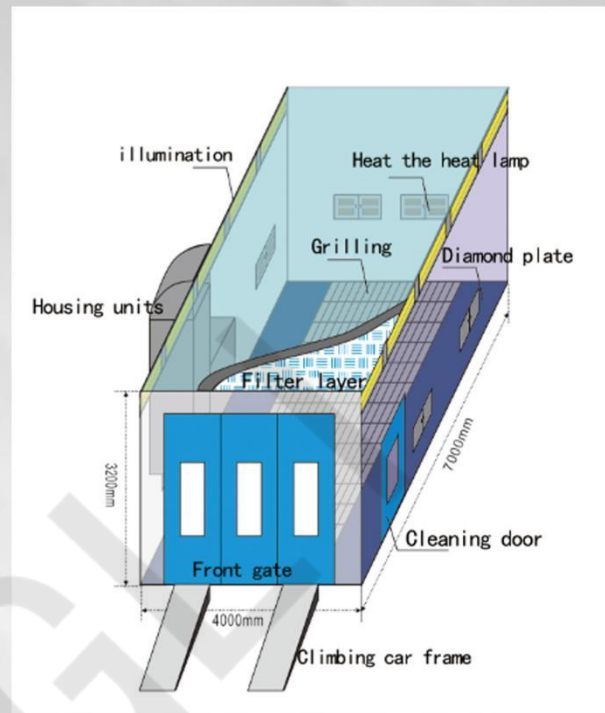

## OIL BURNER SPRAY BOOTH DB-500



Technical Parameters	
Model no.	DB-500
External dimension	7000mm × 4000mm × 3200mm (276*157*126in)
Internal dimension	6900mm × 3900mm × 2650mm (271*154*104in)
Gate	3000mm × 2600mm (118-102in)
Service door	650mm × 1800mm (26-71in)
Voltage frequency	380V, 50HZ
Total power	16.5KW
Cbm	ABOUT 18
Gross weight	ABOUT 2TONS
Container	FEET

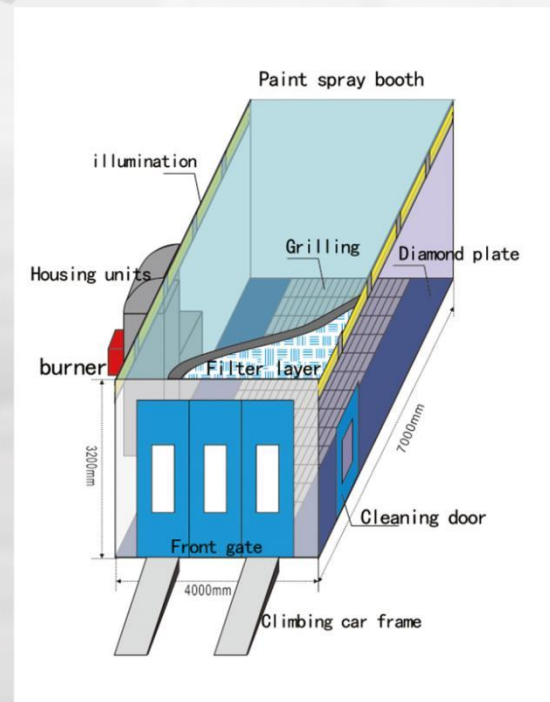

## CHASSIS SUSPENSION ABNORMAL SOUND DETECTION EQUIPMENT



Technical parameters	
Model no.	JL-660 LCD-ST
Name of product	Chassis suspension abnormal sound detection equipment
Lift up weight	4500kg
Duration of jitter	0.6-60s
Operating temperature	-10° to ±50°
Dimensions of packing	870*820*1100mm*2
Net weight	658kg(1433lb) (Set of 4 pieces)
Operating voltage	2P 220V 50/60HZ 15A or 3P 380V 50/60HZ 6A
Composition of equipment	Main equipment *2+ stress release *2+ support frame *2

### Characteristics of equipment

- ① Stable and safe
- ② solid material
- ③ Noise reduction
- ④ quality assurance
- ⑤ Accurate detection



Frequency conversion motor



Gravity inverter



Air protection switch



Axial fan



Drive shaft connected to the plate



Touchscreen control panel

### »»» Operation process

1. Drive the vehicle to the designated construction location, lift the vehicle to a certain height with a double-column lifting platform, move the testing equipment to the front wheel position, move the rear wheel safety bracket to the rear wheel, and move the lifting platform about 100mm away from the vehicle chassis. Let the vehicle chassis force the equipment on the V-shaped plate, adjust all the fixing screws of the equipment, let the casters leave the ground about 5mm and lock them.
2. In order to ensure that the vehicle fully simulates the road driving conditions, release the handbrake, start the testing equipment, and then you can simulate the driving state.

## CHASSIS SUSPENSION ABNORMAL SOUND DETECTION EQUIPMENT



Technical parameters	
Model no.	JL-660 (Butt-T)
Name of product	Chassis suspension abnormal sound detection equipment
Lift up weight	4500kg
Duration of jitter	0.6-60s
Operating temperature	-10° to ±50°
Dimensions of packing	870*820*1100mm*2
Net weight	658kg(1433lb) (Set of 4 pieces)
Operating voltage	2P 220V 50/60HZ 15A or 3P 380V 50/60HZ 6A
Composition of equipment	Main equipment *2+ stress release *2+ support frame *2

### Characteristics of equipment

- ① Stable and safe
- ② solid material
- ③ Noise reduction
- ④ quality assurance
- ⑤ Accure detection



Stress releaser

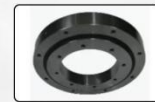

Spindle bearing



Variable-frequency motor



Frequency converter



Bearing steel shaft

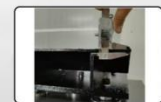

Thickened anti-slip board

### »»» Operation process

1. Drive the vehicle to the designated construction location, lift the vehicle to a certain height with a double-column lifting platform, move the testing equipment to the front wheel position, move the rear wheel safety bracket to the rear wheel, and move the lifting platform about 100mm away from the vehicle chassis. Let the vehicle chassis force the equipment on the V-shaped plate, adjust all the fixing screws of the equipment, let the casters leave the ground about 5mm and lock them.
2. In order to ensure that the vehicle fully simulates the road driving conditions, release the handbrake, start the testing equipment, and then you can simulate the driving state.

### NEW ENERGY LIFTING MACHINE ELECTRICITY



Technical parameters	
Model	JL-220N
Lifting capacity	1000kg/1500kg (Optional)
Scissor arm thickness	20mm
Length of table	1250mm
Width of table	800mm
Voltage	220v

### NEW ENERGY LIFTING MACHINE PNEUMATIC



Technical parameters	
Model	JL-210N
Lifting capacity	1000kg/1500kg (Optional)
Scissor arm thickness	20mm
Length of table	1250mm
Width of table	800mm
Voltage	220v

### SHEET METAL TOOLS



Vigorously wide type  
Model no.: JL-001



Two way clamp  
Model no.: JL-002



The flat nose clamp  
Model no.: JL-003



Shock  
Model no.: JL-004



Palm clamp  
Model no.: JL-005



Double chain  
Model no.: JL-006



Box clamp two-way  
Model no.: JL-007



Box type clamp  
Model no.: JL-008



Mini clamp two-way  
Model no.: JL-009



Mini pliers  
Model no.: JL-010



Orthogonal universal  
Model no.: JL-011



Double rake body  
Model no.: JL-012



Clamp type clamp  
Model no.: JL-013



Narrow  
Model no.: JL-014



Flat head steel hook  
Model no.: JL-015



Round head steel hook  
Model no.: JL-016



Claw hook  
Model no.: JL-017



Big hook  
Model no.: JL-018



Shear type clamp  
Model no.: JL-019



Nylon strap  
Model no.: JL-020



Safety rope  
Model no.: JL-021



Steel wire rope  
Model no.: JL-022



Guide ring  
Model no.: JL-023



Vice  
Model no.: JL-024



Air operated pump 1.6L  
Model no.: JL-FT1.6



Air operated pump 2.3L  
Model no.: JL-FT2.3



Air operated pump 2.3L  
Model no.: JL-AD2.3



Air operated pump 1.6L  
Model no.: JL-EP1.6



Fixture for four-wheel aligner  
Model no.: JL-025



Corner plate  
Model no.: JL-026

## Auto repair equipment



Smart start charger  
Model no.: W-001



Auto repair tool 85  
Model no.: W-002



Box for storage  
Model no.: W-003



Tool tool car  
Model no.: W-004



Tool cart +420 tools  
Model no.: W-005



Oil pumping pump  
Model no.: W-006



Spring remover  
Model no.: W-007



Work skateboard  
Model no.: W-008



Vacuum tire scraper  
Model no.: W-009



Tire repairing machine  
Model no.: W-010



French vice  
Model no.: W-011



Torque wrench  
Model no.: W-012



Car charger  
Model no.: W-013



Car detector  
Model no.: W-014



Electric welding cutting  
Model no.: W-015



Pneumatic impact wrench  
Model no.: W-016



Refrigerator brake drum (disc) cutting machine  
Model no.: W-017



Refrigerant machine  
Model no.: W-018



Brake oil changer  
Model no.: W-019



Nitrogen gas generator  
Model no.: W-020



2T Engine hanger fixed type  
Model no.: W-021



3T Engine hanger fixed type  
Model no.: W-022



Engine turning frame  
Model no.: W-023



20T Press machine  
Model no.: W-024



32T Press machine  
Model no.: W-025

## Auto repair equipment



300L Belt type air compressor  
Model no.: W-300



Screw type air compressor  
7.5kw+1m<sup>3</sup>+1m<sup>3</sup>  
Model no.: W-7.5



Screw type air compressor  
22kw+3.6m<sup>3</sup>+1m<sup>3</sup>  
Model no.: W-22



Screw Air Compressor  
Model no.: W-2-1



Screw Air Compressor  
Model no.: W-4-1



3T jack single pump  
Model no.: W-3TS



3T jack double pump  
Model no.: W-3TD



5T jack double pump  
Model no.: W-5TD



60 ton folding jack  
Model no.: W-60TF



1 ton trailer jack  
Model no.: W-1T



1.5 ton trailer jack  
Model no.: W-1.5T



3 ton airbag jack  
Model no.: W-3TQ



2 ton vertical jack  
Model no.: W-2TV



5 ton vertical jack  
Model no.: W-5TV



3 ton jack support  
Model no.: W-3TSS



6 ton jack support  
Model no.: W-6TSS



12 ton jack support  
Model no.: W-12TSS



0.5 ton high transporter  
Model no.: W-026



1 ton high transporter  
Model no.: W-027



Pneumatic tire expander  
Model no.: W-028



3 for 1 share  
Model no.: W-029



4 for 1 share  
Model no.: W-030



5 for 1 share  
Model no.: W-031



Air drum reel  
Model no.: W-032



Vacuum tire detonator  
Model no.: W-033



Tire pressure gauge  
Model no.: W-034



Double hammer  
air cannon  
Model no.: W-035



Brake disc  
repair machine  
Model no.: W-036



Nozzle cleaning machine  
Model no.: W-037

## Auto repair equipment



Intelligent measuring pen  
Model no.: W-038



Injector detector  
Model no.: W-039



Automobile paint detector  
Model no.: W-040



Oil water spray gun  
Model no.: W-041



Filter wrench  
Model no.: W-042



150 auto repair tools  
Model no.: W-043



216 auto repair tools  
Model no.: W-044



Dual purpose wrench  
Model no.: W-045



6 piece L wrench  
Model no.: W-046



8/10/12/14/18/24 inch wrench  
Model no.: W-047



Multi-function welding machine  
Model no.: W-048



Welding machine  
Model no.: W-049



Aluminum iron welding machine  
Model no.: W-050



Sheet metal repair machine  
Model no.: W-051



Aluminum repair machine  
Model no.: W-052



Electric wrench  
Model no.: W-053



Table drilling machine  
Model no.: W-054



Tire pressure gauge  
Model no.: W-055



Remove the installer  
Model no.: W-056



Car battery charger  
Model no.: W-057



Voltage tester multimeter  
Model no.: W-058



Electric measuring pen  
Model no.: W-059



Hand pull chain  
Model no.: W-060



Hand hacksaw  
Model no.: W-061



Saw  
Model no.: W-062

## Auto repair equipment



Electric drill  
Model no.: W-063



Combination tap tap  
Model no.: W-064



Hexagon wrench of plum  
Model no.: W-065



G clamp retainer  
Model no.: W-066



Straight nose pliers  
Model no.: W-067



8 inch wire pliers  
Model no.: W-068



Piston disassembling pliers  
Model no.: W-069



Piston ring pliers  
Model no.: W-070



6 inch diagonal nose pliers  
Model no.: W-071



8 inch wire pliers  
Model no.: W-072



Pneumatic air gun wrench  
Model no.: W-073



Vacuum tire exploder  
Model no.: W-074



Engine engine balance rack  
Model no.: W-075



Car maintenance work light  
Model no.: W-076

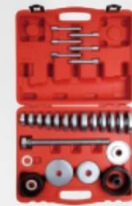

31 bearing removal tools  
Model no.: W-077



Lift Angle disassembly tool  
Model no.: W-078



10 pieces ball head puller  
Model no.: W-079



9 pieces sheet metal hammer  
Model no.: W-080



Pressure washer  
Model no.: W-081



Gearbox cleaning and oil changing machine  
Model no.: W-082



Sheet metal crowbar  
Model no.: W-083



Ball head puller  
Model no.: W-084



Tire repair tool  
Model no.: W-085



Balance block remove clamp hammer  
Model no.: W-086



Block of balance  
Model no.: W-087



Constant speed cabinet  
type disc grinder  
model: W-088



Infinite speed disc machine  
model: W-089



Brake disc dual-purpose  
disc grinder  
model: W-090



Brake disc on the car disc grinder  
model: W-091



Wet and dry vacuum cleaner  
model: W-092



Dry and wet vacuum cleaner  
(with tools)  
model: W-092



MAJOR SERVICES QUALITY



YanTai Jingli  
Automobile Testing  
Equipment Co., Ltd



+0086 18253559136

Wechat/Whatsapp: 008618253559136

Web: <https://en.jingli-ame.com>

Address: NO.251 CHUYU ROAD, ZHICHU COMMUNITY, ZHIFU  
DISTRICT, YANTAI CITY, SHANDONG PROVINCE, CHINA

The final interpretation rights belong to the company, subject to change without prior notice